



Southwest Ranches Town Council

REGULAR MEETING Agenda of January 23, 2025

Southwest Ranches Council Chambers
7:00 PM Thursday

13400 Griffin Road
Southwest Ranches, FL 33330

<u>Mayor</u> Steve Breitreuz	<u>Town Council</u> Jim Allbritton Gary Jablonski	<u>Town Administrator</u> Russell C. Muniz, MBA, MPA	<u>Town Attorney</u> Keith M. Poliakoff, J.D.
<u>Vice Mayor</u> Bob Hartmann	David S. Kuczenski, Esq.	<u>Town Financial Administrator</u> Emil C. Lopez, CPM	<u>Town Clerk</u> Debra M. Ruesga

In accordance with the Americans with Disabilities Act of 1990, persons needing special accommodation, a sign language interpreter or hearing impaired to participate in this proceeding should contact the Town Clerk at (954) 434-0008 for assistance no later than four days prior to the meeting.

1. **Call to Order/Roll Call**
2. **Pledge of Allegiance**

Quasi-Judicial Hearings

Please be advised that the following item on the Council agenda is quasi-judicial in nature. All witnesses who will testify on any item in this portion of the Agenda will be sworn. Participants who are members of the general public need not be sworn and will not be subject to cross-examination if they are not sworn. However, the Council shall not assign un-sworn testimony the same weight or credibility as sworn testimony in its deliberations.

The applicant has the burden of proof. After the applicant's concluding remarks, the hearing will be closed and no additional testimony, material or argument will be allowed unless the Council chooses to request additional testimony. The members of the Town Council will then deliberate.

All evidence relied upon by reasonably prudent persons in the conduct of their affairs may be considered in these proceedings, regardless of whether such evidence would be admissible in a court. Hearsay evidence may supplement or explain other evidence, but shall not alone support a conclusion unless it would be admissible over objection in court. The material in the Town Council agenda will be considered as evidence without authentication.

Anyone representing an organization must present written evidence of his or her authority to speak on behalf of the organization in regard to the matter under consideration. Each person who appears during a public hearing shall identify himself or herself and give their address, and if appearing on behalf of an organization state the name and mailing address of the organization. The Council may, on its own motion or at the request of any person, continue the hearing to a fixed date, time and

place.

No notice shall be required if a hearing is continued to a fixed date, time and place. Any Applicant shall have the right to request and be granted one continuance; however, all subsequent continuance shall be granted at the discretion of the Council and only upon good cause shown.

3. Site Plan Modification for Adrian Fish Market and Restaurant

A RESOLUTION AND FINAL ORDER OF THE TOWN COUNCIL OF THE TOWN OF SOUTHWEST RANCHES, FLORIDA, APPROVING SITE PLAN MODIFICATION APPLICATION NO. SP-87-24 BY SW RANCHES 6670, LLC FOR ACCESSORY OUTDOOR DINING TO THE RESTAURANT AT 6670 DYKES ROAD; AUTHORIZING THE MAYOR, TOWN ADMINISTRATOR, AND TOWN ATTORNEY TO EXECUTE ANY AND ALL DOCUMENTS NECESSARY TO EFFECTUATE THE INTENT OF THIS RESOLUTION; AND PROVIDING AN EFFECTIVE DATE.

Presentations

4. Presentation - Mayor Wayne M. Messam, City of Miramar

5. Presentation - Wyatt Krueger - Eagle Scout Project

6. Presentation by the Broward Metropolitan Organization (MPO) on the proposed US27 Light Rail Project

7. Public Comment

- All Speakers are limited to 3 minutes.
- Public Comment will last for 30 minutes.
- All comments must be on non-agenda items.
- All Speakers must fill out a request card prior to speaking.
- All Speakers must state first name, last name, and mailing address.
- Speakers will be called in the order the request cards were received.
- Request cards will only be received until the first five minutes of public comment have concluded.

8. Board Reports

9. Council Member Comments

10. Legal Comments

11. Administration Comments

Ordinance - 2nd Reading

12. AN ORDINANCE OF THE TOWN OF SOUTHWEST RANCHES, FLORIDA, ESTABLISHING A MINIMUM INTERIOR SPACE REQUIREMENT TO MAINTAIN CANINES WITHIN THE TOWN; PROVIDING FOR INSPECTION; PROVIDING FOR SEVERABILITY AND PROVIDING AN EFFECTIVE DATE.

{Approved on first reading December 12, 2024}

13. AN ORDINANCE OF THE TOWN OF SOUTHWEST RANCHES, FLORIDA; CREATING CHAPTER 28 OF THE TOWN OF SOUTHWEST RANCHES CODE OF ORDINANCES, TO CREATE A CHAPTER ENTITLED PUBLIC CAMPING OR SLEEPING; PROHIBITION; PENALTIES; COMPLAINTS; PROVIDING FOR SEVERABILITY,

PROVIDING FOR CODIFICATION, AND PROVIDING AN EFFECTIVE DATE. {Approved on first reading December 12, 2024}

- 14. AN ORDINANCE OF THE TOWN OF SOUTHWEST RANCHES, FLORIDA, REPEALING AND REPLACING ORDINANCE NO. 2024-003; AMENDING SECTION 9-5 OF CHAPTER 9 ENTITLED "NOISE" OF THE TOWN OF SOUTHWEST RANCHES CODE OF ORDINANCES, TO AMEND THE LIST OF EXEMPTIONS; PROVIDING FOR SEVERABILITY AND PROVIDING AN EFFECTIVE DATE. {Approved on first reading December 12, 2024}**

Resolutions

- 15. A RESOLUTION OF THE TOWN COUNCIL OF THE TOWN OF SOUTHWEST RANCHES, FLORIDA, ADOPTING THE INVESTMENT POLICY IN SUBSTANTIALLY THE SAME FORM AS ATTACHED HERETO AS EXHIBIT "A"; PROVIDING FOR SEVERABILITY; AND PROVIDING FOR AN EFFECTIVE DATE.**
- 16. A RESOLUTION OF THE TOWN COUNCIL OF THE TOWN OF SOUTHWEST RANCHES, FLORIDA, APPROVING A PIGGYBACK OF OMNIA PARTNERS CONTRACT (OMNIA PARTNERS (NCPA)-01-146) FOR THE ISSUANCE OF A PURCHASE ORDER IN AN AMOUNT NOT TO EXCEED THIRTY ONE THOUSAND FIVE HUNDRED TWELVE DOLLARS AND ZERO CENTS (\$31,512.00) TO LENOVO (UNITED STATES) INC. FOR LENOVO LAPTOPS; AUTHORIZING THE MAYOR, TOWN ADMINISTRATOR AND TOWN ATTORNEY TO EXECUTE ALL DOCUMENTS NECESSARY TO EFFECTUATE THE INTENT OF THIS RESOLUTION; AND PROVIDING AN EFFECTIVE DATE.**
- 17. A RESOLUTION OF THE TOWN COUNCIL OF THE TOWN OF SOUTHWEST RANCHES, FLORIDA, REINSTATING THE "PUBLIC SAFETY AND TRAFFIC COMMITTEE" FOR A SIX-MONTH PERIOD, FOR THE PURPOSE OF ADVISING THE TOWN COUNCIL OF PUBLIC SAFETY AND TRAFFIC RELATED ISSUES; PROVIDING FOR THE BOARD'S GOALS, OBJECTIVES, AND LIMITATIONS; PROVIDING FOR THE APPOINTMENT OF BOARD MEMBERS; AND PROVIDING FOR AN EFFECTIVE DATE.**

Discussion

- 18. Timeline for Construction of New Homes**
- 19. Revision of the Certificate of Use Process**
- 20. Event Permit Notification Requirement**
- 21. Vacation of Town Rights of Way - Council Member Jablonski**
- 22. Approval of Minutes**
 - a. September 26, 2024 Regular Meeting Minutes**
 - b. October 16, 2024 Regular Meeting Minutes**
 - c. October 24, 2024 Regular Meeting Minutes**
 - d. November 21, 2024 Regular Meeting Minutes**

23. Adjournment

PURSUANT TO FLORIDA STATUTES 286.0105, THE TOWN HEREBY ADVISES THE PUBLIC THAT IF A PERSON DECIDES TO APPEAL ANY DECISION MADE BY THIS COUNCIL WITH RESPECT TO ANY MATTER CONSIDERED AT ITS MEETING OR HEARING, HE OR SHE WILL NEED A RECORD OF THE PROCEEDINGS, AND THAT FOR SUCH PURPOSE, THE AFFECTED PERSON MAY NEED TO ENSURE THAT A VERBATIM RECORD OF THE PROCEEDING IS MADE, WHICH RECORD INCLUDES THE TESTIMONY AND EVIDENCE UPON WHICH THE APPEAL IS TO BE BASED. THIS NOTICE DOES NOT CONSTITUTE CONSENT BY THE TOWN FOR THE INTRODUCTION OR ADMISSION OF OTHERWISE INADMISSIBLE OR IRRELEVANT EVIDENCE, NOR DOES IT AUTHORIZE CHALLENGES OR APPEALS NOT OTHERWISE ALLOWED BY LAW.



Town of Southwest Ranches
13400 Griffin Road
Southwest Ranches, FL 33330-
2628

(954) 434-0008 Town Hall
(954) 434-1490 Fax

Town Council
Steve Breitreuz, Mayor
Bob Hartmann, Vice Mayor
Jim Allbritton, Council Member
Gary Jablonski, Council Member
David S. Kuczenski, Esq., Council
Member

Russell C. Muniz, MBA, MPA, Town Administrator
Keith M. Poliakoff, JD, Town Attorney
Debra M. Ruesga, Town Clerk
Emil C. Lopez, CPM, Town Financial Administrator

COUNCIL MEMORANDUM

TO: Honorable Mayor Breitreuz and Town Council
VIA: Russell Muñiz, Town Administrator
FROM: Jeff Katims, Town Planner
DATE: 1/23/2025
SUBJECT: Site Plan Modification for Adrian Fish Market and Restaurant

Recommendation

Approval with conditions enumerated in the staff report and resolution.

Unanimous Vote of the Town Council Required?

Yes

Strategic Priorities

A. Sound Governance

E. Cultivate a Vibrant Community

Background

Adrian Fish Market & Restaurant requests a site plan modification to allow a small outdoor dining area.

Fiscal Impact/Analysis

N/A

Staff Contact:

Jeff Katims, Town Planner

ATTACHMENTS:

Description	Upload Date	Type
Resolution - TA Approved	1/16/2025	Resolution
Staff report	1/14/2025	Executive Summary
Site Plan	1/14/2025	Backup Material
Detailed plan for outdoor seating	1/14/2025	Backup Material
Landscape plan	1/14/2025	Backup Material
Draft parking easement agreement	1/14/2025	Backup Material
Survey	1/14/2025	Backup Material
Mail Notice Radius Map	1/14/2025	Backup Material
Mailing list	1/14/2025	Backup Material

RESOLUTION NO. 2025-XXX

A RESOLUTION AND FINAL ORDER OF THE TOWN COUNCIL OF THE TOWN OF SOUTHWEST RANCHES, FLORIDA, APPROVING SITE PLAN MODIFICATION APPLICATION NO. SP-87-24 BY SW RANCHES 6670, LLC FOR ACCESSORY OUTDOOR DINING TO A RESTAURANT LOCATED AT 6670 DYKES ROAD; AUTHORIZING THE MAYOR, TOWN ADMINISTRATOR, AND TOWN ATTORNEY TO EXECUTE ANY AND ALL DOCUMENTS NECESSARY TO EFFECTUATE THE INTENT OF THIS RESOLUTION; AND PROVIDING AN EFFECTIVE DATE.

WHEREAS, SW Ranches 6670, LLC is the current owner ("Owner") of 6670 Dykes Road (the "Property") legally described in Exhibit "A" to this Resolution; and

WHEREAS, Owner requests site plan modification for 451 square feet of outdoor dining area; and

WHEREAS, the Town Council of the Town of Southwest Ranches, Florida ("Town Council") finds that the proposed site plan amendment will comply with the requirements of the Town's Unified Land Development Code ("ULDC") upon implementation of the conditions set forth herein.

NOW, THEREFORE BE IT RESOLVED BY THE TOWN COUNCIL OF THE TOWN OF SOUTHWEST RANCHES, FLORIDA:

Section 1. That the foregoing "WHEREAS" clauses are hereby ratified and confirmed as being true and correct and are hereby made a specific part of this Resolution.

Section 2. That, upon reviewing the application, analysis of the Town Staff, testimony and the evidence submitted at a duly noticed public hearing held on January 23, 2025, the Town Council hereby approves Site Plan Application No. SP-87-24 for the Property as legally described in Exhibit "A" attached hereto and made a part hereof, in accordance with the following stipulated conditions:

1. Prior to issuance of any Town permits for construction of the outdoor dining area, i) the property owner shall enter into a parking easement with Lowes approved as to form by the Town Attorney, that allocates at least 10 adjacent parking spaces to the restaurant and ii) the easement shall be recorded in the Public Records of Broward County.

2. The operation of the outdoor dining area is contingent upon the parking easement remaining in full force and effect. Should the parking easement terminate, the outdoor seating shall be removed immediately. If alternate off-site parking is not secured in accordance with the ULDC, the area approved by this application for the outdoor seating shall be restored to its sodded and irrigated condition within 24 months of the easement termination.

Section 3. The Mayor, Town Administrator, and Town Attorney are each authorized to execute any and all documents necessary to effectuate the intent of this Resolution.

Section 4. This Resolution shall become effective immediately upon adoption.

PASSED by the Town Council of the Town of Southwest Ranches, Florida, this 23rd day of January 2025 on a motion by _____ and seconded

by _____.

Breitkreuz	_____
Hartmann	_____
Allbritton	_____
Jablonski	_____
Kuczenski	_____

Ayes	_____
Nays	_____
Absent	_____
Abstaining	_____

Steve Breitkreuz, Mayor

ATTEST:

Debra Ruesga, CMC, Town Clerk

Approved as to Form and Correctness:

Keith Poliakoff, Town Attorney
1001.002.2025

Exhibit "A"

Legal Description

A portion of parcel a of the plat of "Coquina Flats" as recorded in Plat Book 155, Page 29 of the public records of Broward County, Florida, being more particularly described as follows:

Commence at the Northwest corner of the Southwest one-quarter of Section 4, township 51 South, range 40 East; thence South 01 degrees 42 minutes 28 seconds East along the West line of said Southwest one-quarter, a distance of 1572.30 feet; thence North 88 degrees 17 minutes 32 seconds East a distance of 61.04 feet to the point of beginning; thence continue North 88 degrees 17 minutes 32 seconds East a distance of 173.98 feet; thence South 01 degrees 45 minutes 42 seconds East a distance of 278.66 feet; thence South 88 degrees 17 minutes 32 seconds West a distance of 178.27 feet to a point on the East right-of-way line of Dykes Road, according to said plat; thence North 09 degrees 36 minutes 07 seconds East a distance of 61.19 feet; thence North 01 degrees 42 minutes 28 seconds West a distance of 100.00 feet; thence North 20 degrees 08 minutes 34 seconds West a distance of 37.95 feet; thence North 01 degrees 42 minutes 28 seconds West a distance of 49.00 feet; thence North 05 degrees 08 minutes 06 seconds East a distance of 33.89 feet to the point of beginning; (the preceding five courses being coincident with said East right-of-way line)

**This page
intentionally left blank**

**TOWN OF SOUTHWEST RANCHES
TOWN COUNCIL AGENDA REPORT**

- DATE:** January 23, 2025
- SUBJECT:** Site Plan Modification, Application No. SP-87-24; Adrian Fish Market & Restaurant
- ADDRESS:** 6670 Dykes Road
- PETITIONER/
OWNER:** SW Ranches 6670, LLC
- AGENT:** Adrian Benitez
- ZONING:** CB, Community Business District
- LAND USE PLAN
DESIGNATION:** Commercial
- REQUEST:** Site plan modification to add outdoor seating for the restaurant.
- EXHIBITS:** Staff Report, Aerial Photograph, Site Plan, Draft Parking Easement, and Mail Notification Radius Map and Mailing List.

DETAILED REQUEST AND ANALYSIS:

SW Ranches 6670, LLC is applying for approval to add 451 square feet of outdoor dining area to the Adrian Fish Market & Restaurant that opened late last year at 6670 Dykes Road. The outdoor dining area would be located at the northeast corner of the restaurant between the building and sidewalk.

Brick pavers would replace the existing sod within the proposed outdoor dining area. The site would continue to comply with the minimum pervious area requirement (30% required, 33.6% provided). Existing site landscaping was inspected and generally found to be acceptable and code-compliant. The plan proposes some additional palms, shrubs and groundcover, predominantly at the front of the restaurant.

Additional parking spaces are required for the outdoor seating area. The site cannot accommodate additional parking spaces, but Lowes has agreed to lease adjacent parking spaces to the property owner for as long as Adrian Fish Market & Restaurant operates on the site. Lowes has ample surplus parking adjacent to the site.

STAFF RECOMMENDATION:

Staff finds that the site plan complies with the requirements of the Unified Land Development Code subject to the following conditions:

1. Prior to issuance of any Town permits for construction of the outdoor dining area, i) the property owner shall enter into a parking easement with Lowes approved as to form by the Town Attorney that allocates at least 10 adjacent parking spaces to the restaurant and ii) the easement shall be recorded in the Public Records of Broward County.
2. The operation of the outdoor dining area is contingent upon the parking easement remaining in full force and effect. Should the parking easement terminate, the outdoor seating shall be removed immediately. If alternate off-site parking is not secured in accordance with the ULDC, the area approved by this application for the outdoor seating shall be restored to its sodded and irrigated condition within 24 months of the easement termination.

SP-87-24 Aerial Location Map

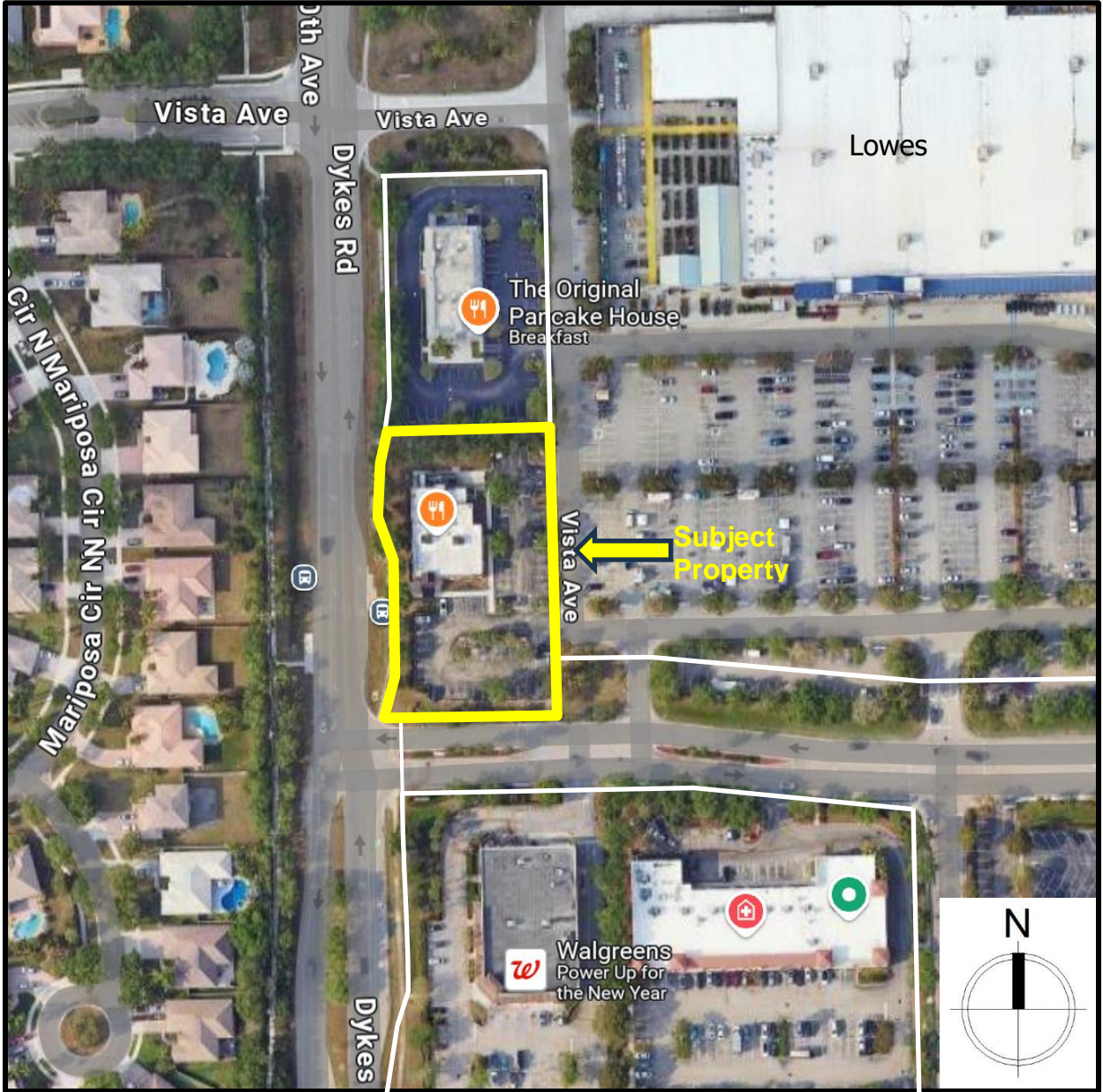

Close-up Aerial

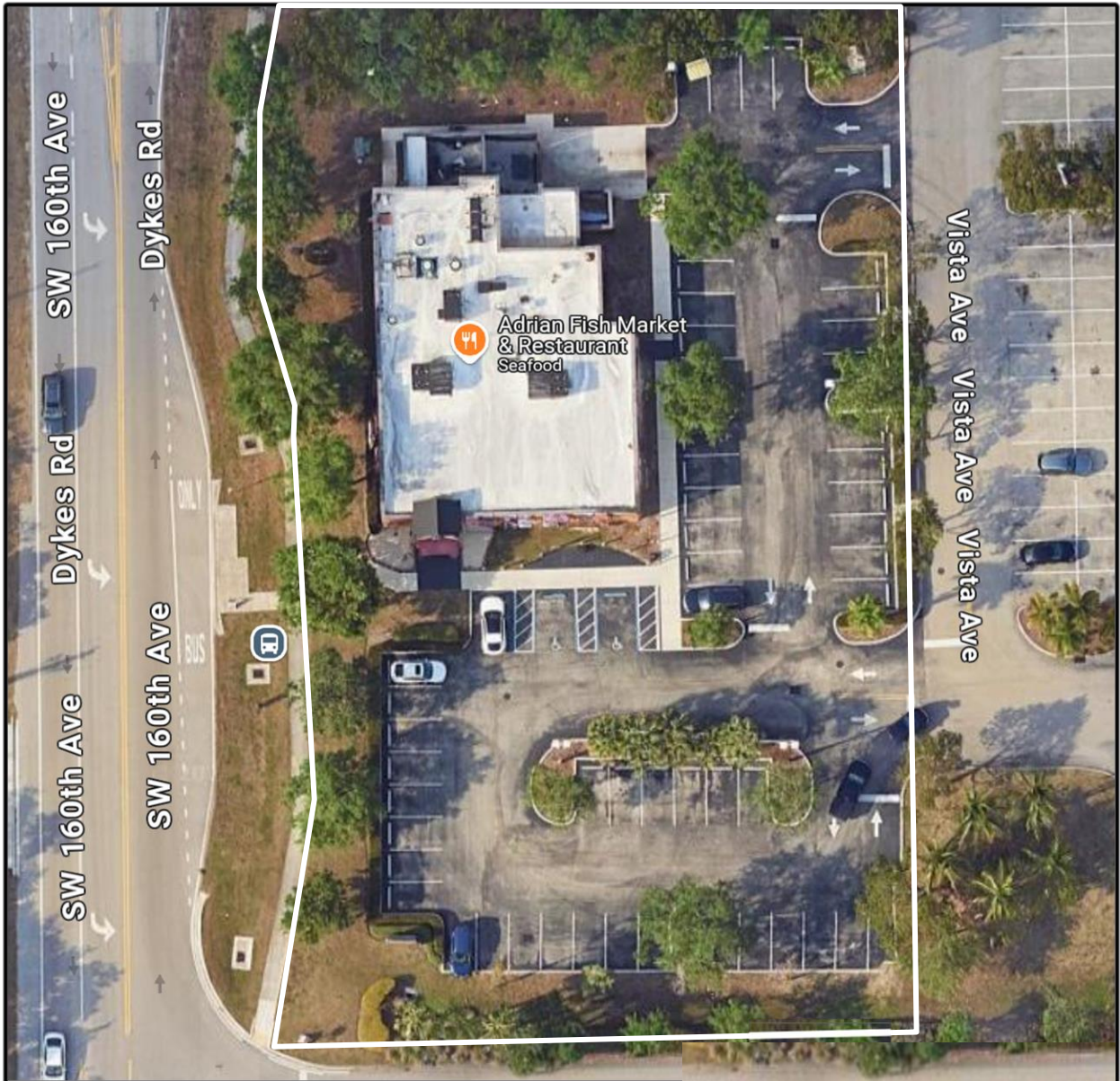

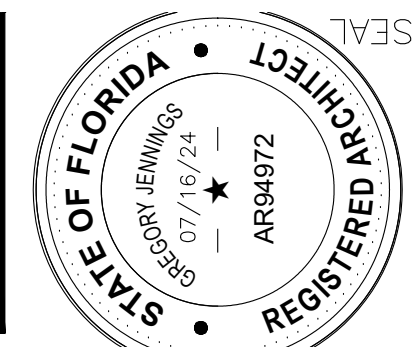

NOTE: THIS ITEM HAS BEEN DIGITALLY SIGNED AND SEALED BY REGISTERED PROFESSIONAL ARCHITECT JOHN M. JAS. DATE OF 07/16/2024. THIS DOCUMENT IS NOT VALID UNLESS THE ORIGINAL SIGNED COPY OF THIS DOCUMENT IS PRESENT. THE SIGNATURE MUST BE VERIFIED ON ANY ELECTRONIC COPIES.

ADRIAN'S FISH RESTAURANT - PROPOSED OUTDOOR SEATING AREA
 6670 DYKES ROAD
 SOUTHWEST RANCHES, FLORIDA (BROWARD COUNTY)
 OUTDOOR SEATING AREA

Comm. No. 241103
 Date: July 16, 2024
 Scale: 3/8" = 1'-0"
 Drawn: JULIO A.
 Checked: A.J.V.
 Appvd: A.J.V.

Sheet No. **SP-01A**
 OF

SCHEMATIC PROGRESS SET JULY 16, 2024

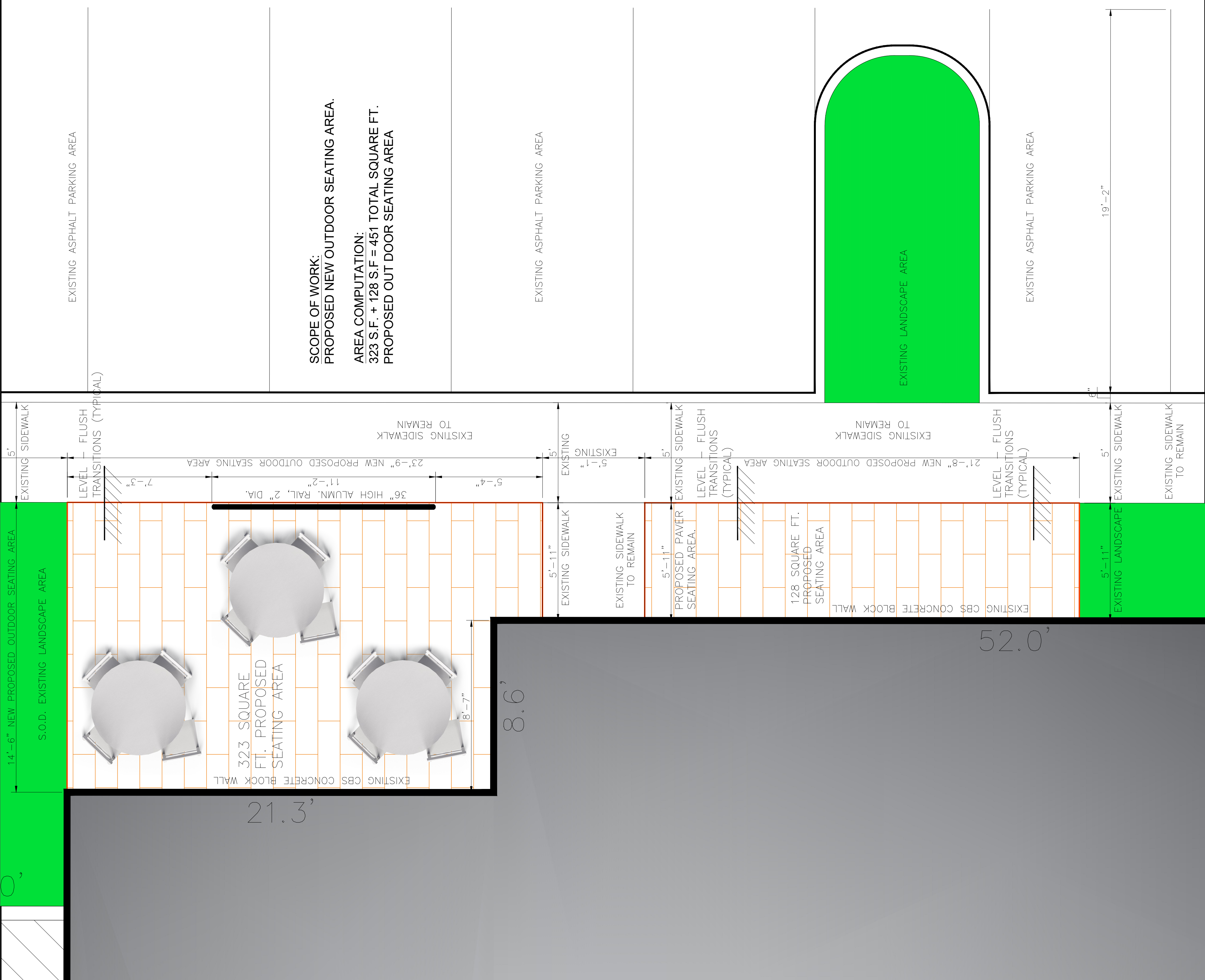

LEGEND:

- ACCESSIBLE TABLE LOCATION
- NEW PROPOSED TABLE AND CHAIR
- NEW PROPOSED SEATING AREA PAVERS
- 36" H. ALUMN. RAIL TO CONTAIN SEATING AREA

PRODUCT : NEW MIAMI 2 3/8"

SPECIFICATIONS
 5F X PALLET: 98
 PCS X PALLET: 272
 PCS X SF: N/A

PATTERN: RANDOM
COLOR: NEW MIAMI
 8 1/2" x 8 1/2" x 2 3/8"
 THICKNESS - 2.38"

DESCRIPTION

The charm of the New Miami paver comes from its "aged" appearance. Some say it is "technology creating tradition". It is actually returning to the old with the new.

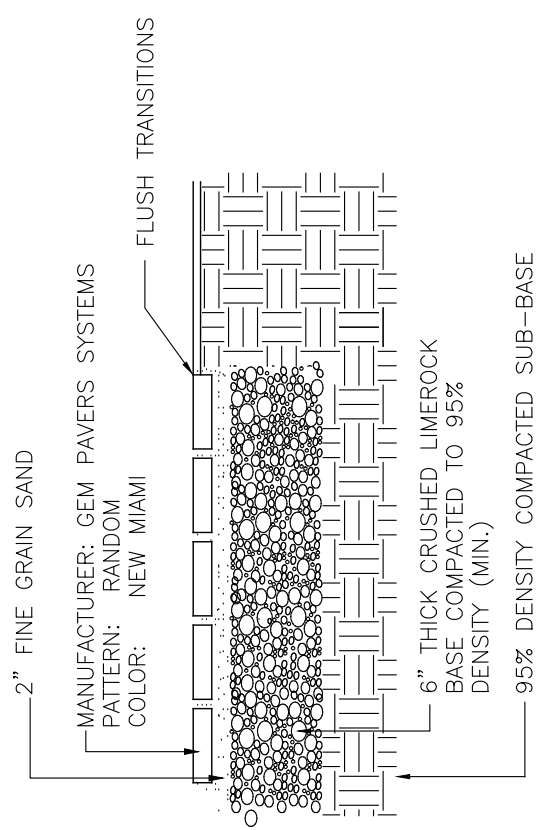

PAVER INFORMATION:

MANUFACTURER: GEM PAVERS SYSTEMS
PATTERN: RANDOM
COLOR: NEW MIAMI

MANUFACTURER INFORMATION:
 GEM PAVERS SYSTEMS
 9645 NW 118TH WAY
 MEDLEY, FL 33178

CONTACT:
 PHONE: 305-805-0000
 FAX: 305-805-0004
 INFO@GEMPAVERS.COM

PAVER DETAIL AND INFORMATION

SCALE NTS.

GENERAL LANDSCAPE NOTES

- The plan takes precedence over the plant list.
- Plant lists are provided for reference only. For more information, call 1-800-432-4770, Sunshine State Nursery, 10000 W. US Highway 1, Fort Lauderdale, FL 33309.
- One call of Florida's "No-Dig" program is required for coordinating with the owners and appropriate public agencies to assist in locating and verifying all underground utilities prior to excavation. All existing utilities shown on the plans are to be considered approximate and should be verified by the contractor prior to the start of work operations.
- General site and berm grading to +/- 1 inch (1") shall be provided by the general contractor. All finished site grading and final decorative berm shaping shall be provided by the landscape contractor. The plans are to be considered Minimum. All plant material must meet or exceed these minimum requirements for both height and spread. Any other requirements for specific shape or effect as noted on the plan(s) will also be required for final acceptance.
- All plant material furnished by the landscape contractor shall be Florida #1 or better as established by Grades and Standards for Florida Nursery Trees and Plants. All trees designated as single trunk shall have a single, relatively straight, dominant leader, proper structural branching and even branch distribution. Trees with bark inclusion, tipped branches, and co-dominant trunks will not be accepted. Trees with gridding, circling and/or plunging roots will be rejected.
- All planting beds shall be free of all rocks 1/2" or larger, sticks, and all objectionable non-native material including weeds, weed seeds. All linerrock, road rock, asphalt shall be removed/cleaned down to the native soils. Planting soil 50/50 sand/topsoil mix shall be delivered to the site in a clean loose and friable condition and is required around the root ball of all trees and palms. The top 2" of all plants to be planted shall be placed in the existing soil after the planting soil has been placed. The plants shall be placed in the planting soil and sticks. Recycled compost is encouraged as a soil amendment alternative to all bark. All burlap, string, cords, wire baskets, plastic or metal containers shall be removed from the rootballs before planting. Remove all bamboo and metal nursery stakes. Remove all tagging tape.
- All trees/palms shall be planted so the top of the root ball, root fair is slightly above final grade. Shrub material shall be planted such that the top of the plant ball is flush with the surrounding grade. It is the sole responsibility of the landscape contractor to ensure that all new plantings receive adequate water during the installation and during all maintenance periods. Adequate watering of new trees and shrubs shall be provided. The contractor shall be responsible for providing proper plant development and shall be provided as a part of this contract.
- All trees/palms shall be staked using biodegradable material. No wire, black strapping, or other synthetic material shall be used. Nailing into trees and palms for any reason is prohibited and the material will be rejected. Please refer to the planting details. All landscape and lawn areas are irrigated by an existing fully automatic sprinkler system with a minimum 100% coverage with all heads adjusted to 50% overlap. One bubbler shall be provided for each tree. The system is operational with a rain sensor.
- No fertilizers required.
- All landscape areas shall be covered with a 3" layer of Melaleuca mulch or Flammuch when set. Spread mulch to 1" thickness 3" away from the trunks/stems of all plant material. All trees in sodded areas shall have a clean cut 4" diameter mulch ring. The 5-6" height water ring shall be made from mulch, not soil. Certain areas may receive a thicker mulch cover where noted on plans. Express, red, gold and green mulch is prohibited.
- All open areas not covered by trees, palms, shrubs, vines or ground covers shall receive Sterotrophum secundatum, St. Augustine "Palmetto" sod, whether labeled on the plans or not, unless a different species is indicated on the planting plan. All noted s.t. shall be approximate. It is the contractor's responsibility to do his or her take off and sod all open areas. It shall be the responsibility of the contractor to include in the bid, the repair of any existing sod which may be damaged during construction. To the planting details for a graphic representation of the above notes.
- All ideas, designs and plans indicated or represented by this drawing are owned by and are the exclusive property of Thomas L. White, ASLA-ISA.
- All plant material as included herein shall be warranted by the landscape contractor for a minimum period as follows: All trees and palms for 12 months, all shrubs, vines, groundcovers and miscellaneous planting materials for 90 days, and all lawn areas for 60 days after final acceptance by the owner or owner's representative. A min. 5 feet horizontal clearance / horizontal separation is required between city utilities infrastructure and proposed small trees and 10 foot separation from large trees.

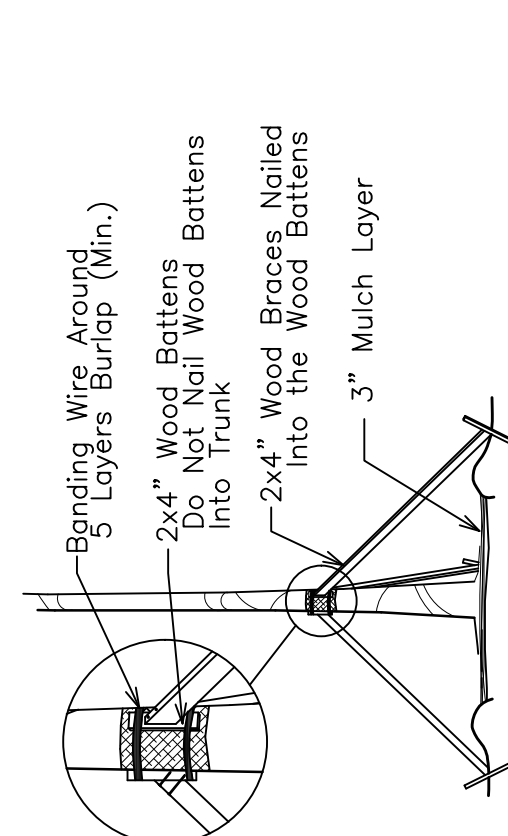

TREE/PALM BRACING DETAIL
NTS

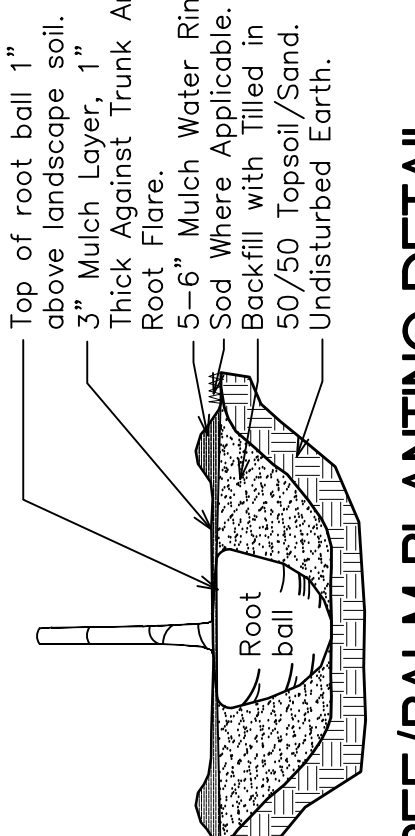

TREE/PALM PLANTING DETAIL
NTS

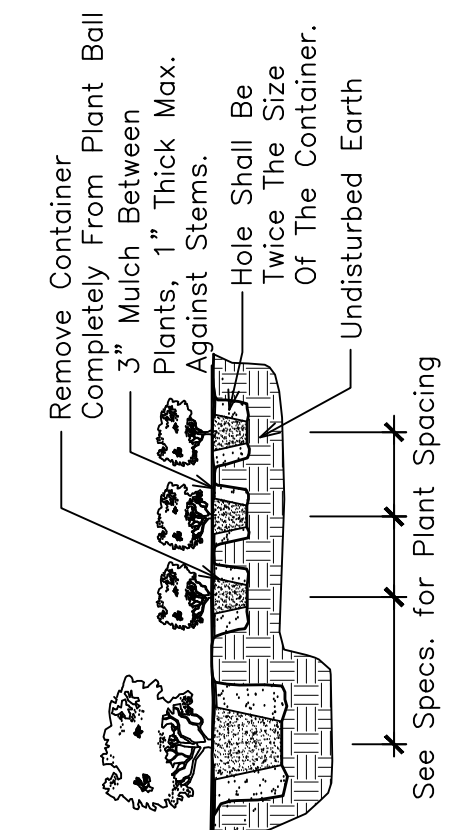

SHRUB PLANTING DETAIL
NTS

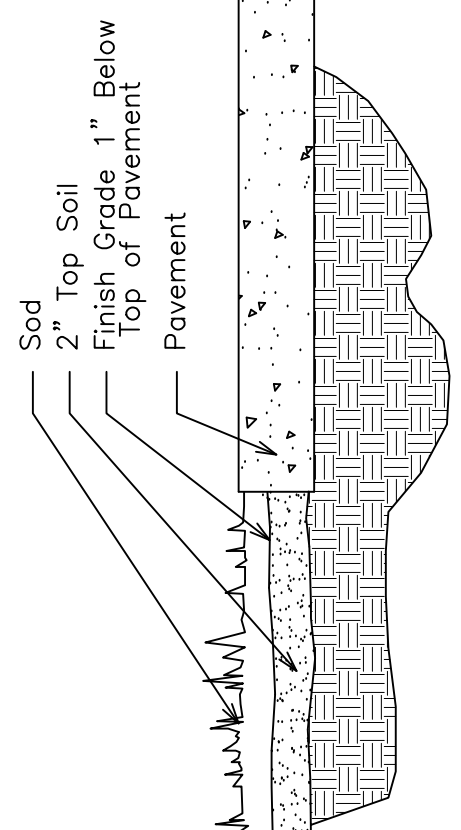

SOD INSTALLATION DETAIL
NTS

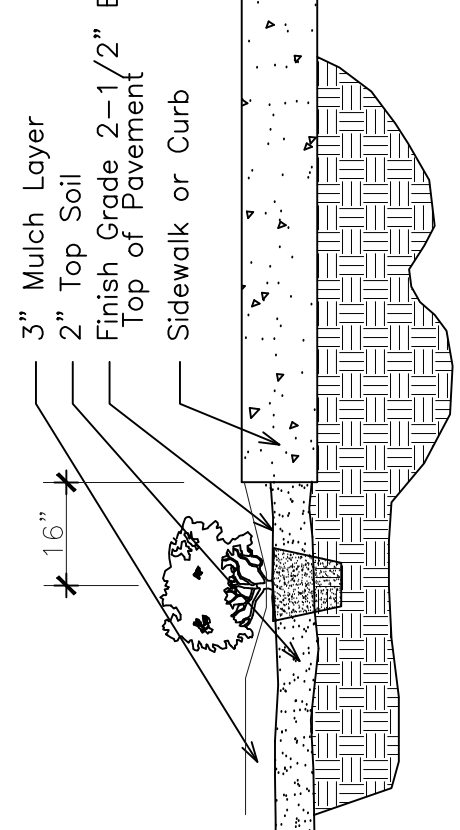

SHRUB INSTALLATION DETAIL
NTS

- EXISTING PLANT MATERIALS LEGEND**
- LIVE OAK
 - GREEN BUTTONWOOD
 - BALD CYPRESS
- PALMS**
- CABBAGE PALM
 - ROYAL PALM
- SHRUBS / GROUND COVER**
- RED TIP COCOPLUM
 - FAKAHATCHEE GRASS
 - WAX JASMINE

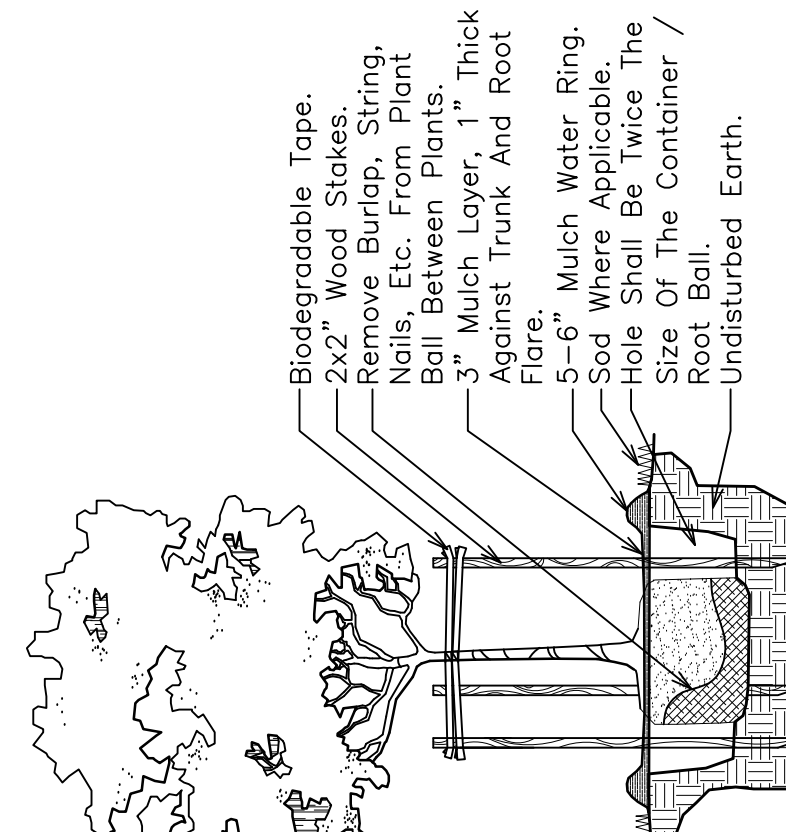

SMALL TREE PLANTING DETAIL
NTS

- TYPICAL SHRUB SPACING DETAIL**
NTS
- C: 18" for all 1 gal., 30" for all 3 gal. or greater, vines not included
- A: 14" for all 1 gal., 24" for all 3 gal. or greater.

Dykes Road

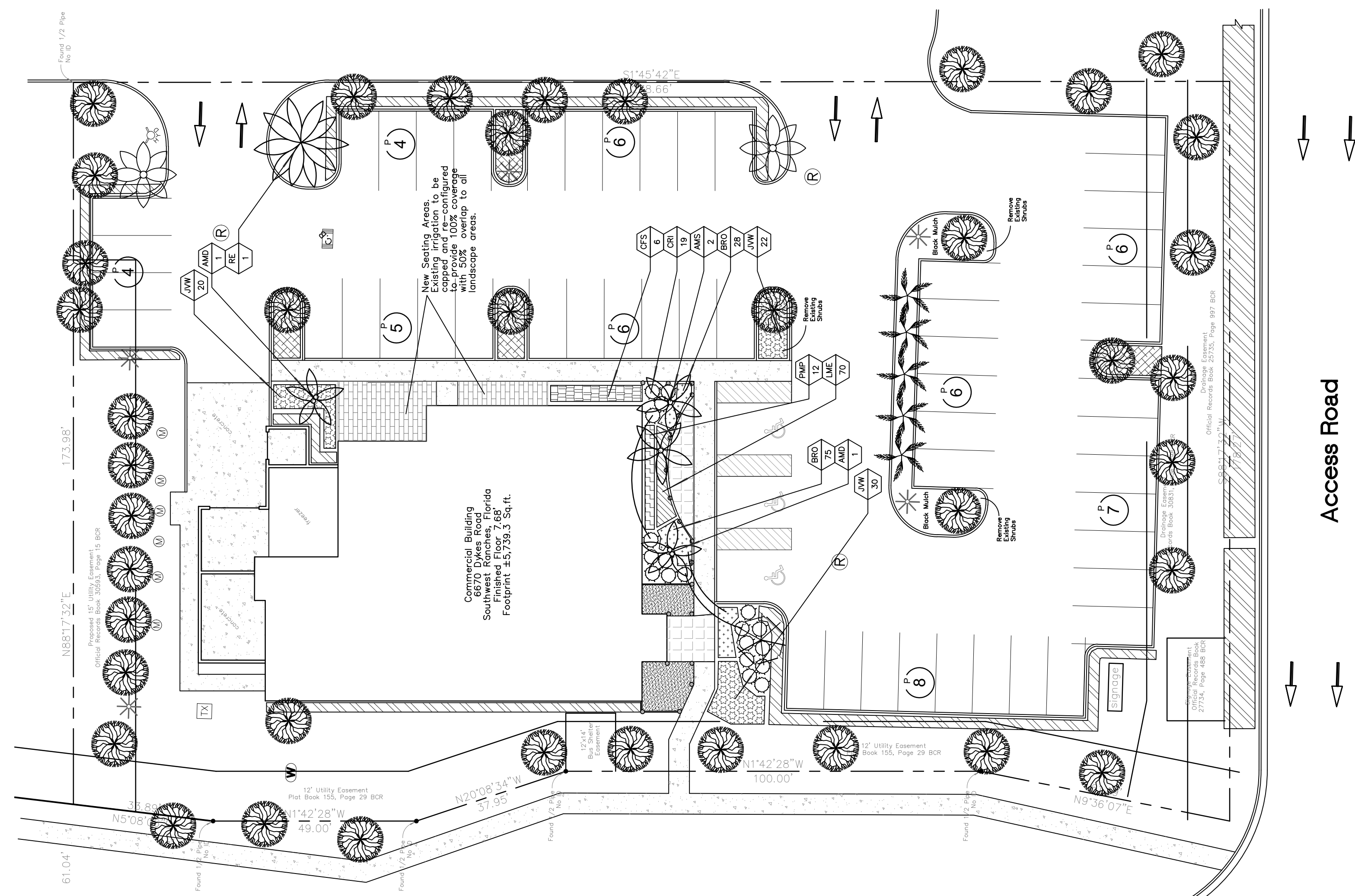

Access Road

Sunshine811
Call 811 or www.sunshine811.com two full business days before digging to have utilities located and marked.
Check positive response codes before you dig!

Code	Drought QTY.	Botanical Name / Common Name	Specifications
PROPOSED PALMS			
AMD	2	Adonidia merrillii / Christmas Palm	8 CT. Double Trunk
AMS	V	Adonidia merrillii / Christmas Palm	8 CT. Single Trunk
RE	1	Roystonea elata / Cuban-Florida Royal Palm	8 GW
ACCENTS / SHRUBS			
CPS	6	Clusia flava / Small Leaf Clusia	7 Gall. 42"x24" 36" OC
CRI	19	Crinum maritimum / Burgandy Chinum	3 x 3'
PMP	12	Podocarpus macrophyllus / Podocarpus	3 Gall. 24"x18" 2' OC
GROUND COVERS / TURF / MISC.			
BRO	103	Bromeliad spp. / Assorted Colors	1 Gall. Full, 12:15' OC
JWW	72	Jasminum volatile / Wax Jasmine	3 Gall. 15" Spn., 2' OC
LME	70	Liriodaphne muscari / Liriope Evergreen Giant	12" OA HI., 8-9' OC
Root Barrier	182 L.F.	Century Deep Root or Equal	18"
SOIL	25 C.Y.	50/50 Topsoil/Sand	Per Planting Details
	(N)	Florida Native Plant Species	
	(M)	Moderate Drought Tolerance	
	(V)	Very Drought Tolerant	

THOMAS WHITE, ASLA-ISA
LANDSCAPE ARCHITECT, LEED GREEN ASSOCIATE, CERTIFIED ARBORIST
tcwhite@bellsouth.net
954-253-2265

Tree Survey-Disposition Plan / Landscape Permit Plan
6670 Dykes Road
Southwest Ranches, Florida 33331



DRAWN: TW
CHECKED: CHW
DATE: 8-29-2024
SCALE: 1"=20'

Sheet No. L-1
Sheet 1 of 1

**This page
intentionally left blank**

PREPARED BY AND RETURN TO:

Jeffrey P. Orlan, Esq.
Jeffrey P. Orlan, P.A.
3 Fieldcrest Drive
New City, NY 10956

ACCESS AND PARKING EASEMENT AGREEMENT

THIS ACCESS AND PARKING EASEMENT AGREEMENT (“Agreement”) is made and entered into this ___ of _____ 2025 by and between Lowe’s Home Centers, LLC, a North Carolina limited liability company fka Lowe’s Home Centers, Inc. (“Grantor”) and SW Ranches 6670, LLC, a Florida limited liability company (“Grantee”).

WHEREAS:

A. Grantor is the owner of that certain parcel of land located in the City of Southwest Ranches, State of Florida, as more particularly identified and described in Exhibit “A” attached hereto and made a part hereof (the “Grantor’s Parcel”).

B. Grantee is the owner of that certain parcel of land located adjacent to the Grantor's Parcel, as more particularly identified, and described in Exhibit “B” attached hereto and made a part hereof (the “Grantee’s Parcel”).

C. Grantor has agreed with Grantee to grant to Grantee a perpetual, non-exclusive easement in favor of and appurtenant to Grantee’s Parcel over the Parking Parcel (as defined herein) for vehicle parking on and ingress and egress to and from Grantor’s Parcel.

NOW, THEREFORE, for and in consideration of the premises, and other good and valuable consideration, the receipt and sufficiency of which are hereby acknowledged, the parties hereby agree as follows:

1. Recitals. The foregoing recitals are true and correct and are incorporated herein by this reference.
2. Grant. Grantor hereby grants to Grantee a perpetual, non-exclusive easement (the “Parking Easement”) in favor of and appurtenant to Grantee’s Parcel over the portion of the Grantor’s Parcel containing ten (10) parking spaces as identified on Exhibit “C” attached hereto and made a part hereof (the “Parking Parcel”) for the sole and exclusive purpose of passenger vehicle parking for, and pedestrian and vehicular traffic of, customers of Grantee and operators of Grantee’s Parcel. Grantee acknowledges and agrees that it shall not permit Grantee’s employees to park on the Parking Parcel.
3. Maintenance. The cost of maintaining the Parking Parcel shall be borne exclusively by Grantor; provided, however, any cost and expense relating to said maintenance by Grantor which is directly attributable to the negligence or deliberate act(s) or omission(s) excluding, however, normal wear and tear, of Grantee, its tenants, employees, licensees, customers, business invitees, and/or guests shall be the responsibility and expense of Grantee.
4. Indemnification. Grantee hereby indemnifies and agrees to defend and hold harmless Grantor from and against all liabilities, damages, claims, costs, and expenses whatsoever (including

reasonable attorney's fees and court costs at all trial and appellate levels) arising out of or in connection with Grantee's use of Grantor's Parcel and the Parking Parcel.

5. Fee. As consideration for the granting of the Easements, Grantee shall pay to Grantor a fee (the "Easement Fee") of one thousand five hundred dollars (\$1,500.00) per annum, said Easement Fee to be due and payable for each calendar year by December 1st of the preceding calendar year. The Easement Fee shall be prorated for any partial calendar year. Simultaneously with the execution of this Agreement, Grantor shall pay to Grantor the prorated Easement Fee for the calendar year 2025.
6. Duration. The easements, restrictions and obligations created and imposed herein shall be effective upon the date hereof and shall inure to the benefit of and be binding upon the parties, their heirs, executors, administrators, successors, successors-in-title, and assigns. Grantee may terminate this Agreement at any time by delivering 30 days' prior written notice to Grantor, in which event either party hereto may record in the Public Records of Broward County, Florida, a termination of this Agreement. The grant of easement shall remain effectively only so long as a Adrian Fish Restaurant Fish Market restaurant, as such restaurants are currently operated under said trade name at the time of this Agreement, is open and operating on Grantee's Parcel. The easements, restrictions and obligations created and imposed herein shall automatically terminate without the need for any additional documentation at such time when said Adrian Fish Restaurant Fish Market restaurant closes or is no longer operating as a Adrian Fish Restaurant Fish Market restaurant.
7. Relocation. Grantor may, upon prior written notice to Grantee, relocate the Parking Easement to another area on Grantor's Parcel (the "Replacement Easement Area"); provided, however, that the Replacement Easement Area shall be an area similarly suited to Grantee's needs as the Parking Parcel (in Grantor's reasonable discretion) and shall contain ten (10) parking spaces.
8. Reservation by Grantor. Grantor reserves all rights of ownership in and to Grantor's Parcel which are not inconsistent with the easements granted herein, including, without limitation, the right to grant further easements on, over or across Grantor's Parcel, provided however that such reserved rights shall not unreasonably impair Grantee's ingress and egress to the Grantor's Parcel, or Grantee's non-exclusive easement rights to the Parking Parcel. Grantor further reserves the right to use Grantor's Parcel for all uses not interfering with the use permitted Grantee hereunder.
9. Successors and Assigns. This Agreement shall be binding upon and inure to the benefit of the parties hereto and their respective successors and assigns.
10. Notice Provision. Any notice required or permitted to be given under this Agreement shall be in writing and shall be deemed to have been given upon deposit with an overnight courier service (such as Federal Express) or upon deposit in the United States Mail as Certified Mail, Return Receipt Requested, postage prepaid, and addressed to the party being notified at the address given below (or such other address which any party may designate for itself from time to time hereafter by written notice to the other parties):

Grantor:
Lowe's Home Centers, LLC
1000 Lowe's Boulevard (PMT62)
 Mooresville NC 28117

With a copy to:

Lowe's Home Centers, LLC
1000 Lowe's Boulevard (LGL64)
 Mooresville NC 28117
Grantee:
SW Ranches 6670, LLC
12391 Pembroke Road
Pembroke Pines, FL 33025
Attn: Cris Vazquez / Property Management

[Signatures commence on next page.]

EXECUTED as of the day and year first above written.

Signed, sealed and delivered in
the presence of:

Lowe's Home Centers, LLC
a North Carolina limited liability company

Print name of witness: _____

By: _____

Name: Richard J. Goodman

Print name of witness: _____

Title: Vice President, Retail Facilities,
Construction and Property Management

STATE OF _____

COUNTY OF _____

The foregoing instrument was acknowledged before me by means of physical presence or
 online notarization, this ____ day of _____ 2025, by _____,
as _____ of Lowe's Home Centers, LLC, a North Carolina limited liability company, on
behalf of the company. He/she is personally known to me or has produced a driver's license or
other: _____ as identification.

[Notary Seal]

Print Name: _____

NOTARY PUBLIC- State of _____

My Commission expires: _____

EXECUTED as of the day and year first above written.

GRANTEE:

SW Ranches 6670, LLC,
a Florida limited liability company

Signed, sealed and delivered in
the presence of:

By: JDV Properties, LLC, a Florida limited
liability company, its Manager

Print name of witness: _____

By: _____

Print Name: _____

Print name of witness: _____

Title: _____

STATE OF FLORIDA

COUNTY OF _____

The foregoing instrument was acknowledged before me by means of physical presence or
 online notarization, this ____ day of _____ 2025 by _____, as Manager of
JDV Properties, LLC, a Florida limited liability company, as Manager of SW Ranches 6670, LLC, a
Florida limited liability company, on behalf of the company. He/she is personally known to me or has
produced a driver's license or other: _____ as identification.

[Notary Seal]

Print Name: _____
NOTARY PUBLIC- State of _____
My Commission expires: _____

**This page
intentionally left blank**

Exhibit "A"
Legal Description – Grantor's Parcel

Parcel I:

A portion of Parcel "A" COQUINA FLATS, according to the plat thereof as recorded in Plat Book 155, page 29, Public Records of Broward County, Florida, being more particularly described as follows:

Commence at the Southeast corner of said Parcel "A"; thence run N1°45'36"W, along the East line of said Parcel "A", for 649.63 feet; thence run S88°14'24"W for 416.67 feet to the POINT OF BEGINNING; thence continue S88°14'24"W for 301.51 feet; thence run N86°11'42"W for 253.20 feet; thence run S88°17'32"W for 118.66 feet; thence run N1°45'42"W for 560.00 feet; thence run S88°17'43"W for 165.77 feet; thence run N1°42'28"W for 100.00 feet; thence run S88°17'32"W for 12.00 feet; thence run N1°42'28"W for 10.00 feet; thence run N5°08'06"E for 100.72 feet; thence run N1°42'28"W for 64.21 feet (the preceding five courses being coincident with the West line of said Parcel "A"); thence run N89°28'30"E for 882.03 feet; thence S1°45'36"E for 741.17 feet; thence run S88°17'34"W for 44.14 feet; thence run S1°45'36"E for 98.88 feet to the POINT OF BEGINNING.

Parcel II:

Non-exclusive Easements as granted by and described in EASEMENT AGREEMENT recorded September 28, 1999 in Official Records Book 29883, page 794 which was amended by MAINTENANCE AND SIGNAGE SPECIFICATION AGREEMENT recorded September 21, 2000 in Official Records Book 30868, page 0901, and by CROSS-ACCESS EASEMENT AGREEMENT recorded September 8, 2000 in Official Records Book 30833, page 1646, Public Records of Broward County, Florida, less any portion thereof lying within Parcel I.

Parcel III:

Non-exclusive Easement for storm water drainage into the (LAKE) (MASTER STORM WATER RETENTION AREA) as granted by and described in EASEMENT AGREEMENT recorded September 28, 1999 in Official Records Book 29883, page 794, and DRAINAGE EASEMENT AGREEMENT recorded September 8, 2000 in Official Records Book 30833, page 1664, all of the Public Records of Broward County, Florida, over those parcels described as follows:

(E5)

A portion of Parcel "A" COQUINA FLATS, according to the plat thereof as recorded in Plat Book 155, page 29, Public Records of Broward County, Florida, and being more particularly described as follows:

Commence at the Southeast corner of said Parcel "A"; thence run N 1°45'36" W, along the East line of said Parcel "A", for 649.63 feet; thence run S 88°14'24" W for 416.67 feet; thence run N 1°45'36" W for 116.09 feet to the Point of Beginning; thence continue N 1°45'36" W for 30.00 feet; thence run N 88°14'10" E for 70.51 feet; thence run S 1°45'36" E for 30.00 feet; thence run S 88°14'10" W for 70.51 feet to the Point of Beginning.

(E6)

A portion of Parcel "A" COQUINA FLATS, according to the plat thereof as recorded in Plat Book 155, page 29, Public Records of Broward County, Florida, and being more particularly described as follows:

Commence at the Southeast corner of said Parcel "A"; thence run N 1°45'36" W, along the East line of said Parcel "A", for 649.63 feet; thence run S 88°14'24" W for 416.67 feet; thence run N 1°45'36" W for 295.79 feet to the Point of Beginning; thence continue N 1°45'36" W for 30.00 feet; thence run N 88°14'10" E for 69.54 feet; thence run S 1°45'36" E for 30.00 feet; thence run S 88°14'10" W for 69.54 feet to the Point of Beginning.

(E7)

A portion of Parcel "A" COQUINA FLATS, according to the plat thereof as recorded in Plat Book 155, page 29, Public Records of Broward County, Florida, and being more particularly described as follows:

Commence at the Southeast corner of said Parcel "A"; thence run N 1°45'36" W, along the East line of said Parcel "A", for 649.63 feet; thence run S 88°14'24" W for 416.67 feet; thence run N 1°45'36" W for 599.19 feet to the Point of Beginning; thence continue N 1°45'36" W for 20.00 feet; thence run N 88°14'18" E for 63.89 feet; thence run S 1°45'36" E for 20.00 feet; thence run S 88°14'18" W for 63.89 feet to the Point of Beginning.

(E8)

A portion of Parcel "A", COQUINA FLATS, according to the plat thereof as recorded in Plat Book 155, page 29, Public Records of Pinellas County, Florida, and being more particularly described as follows:

Commence at the Southeast corner of said Parcel "A"; thence run N 1°45'36" W, along the East line of said Parcel "A", for 649.63 feet; thence run S 88°14'24" W for 416.67 feet; thence run N 1°45'36" W for 821.23 feet to the Point of Beginning; thence continue N 1°45'36" W for 30.00 feet; thence run N 88°14'19" E for 70.90 feet; thence run S 1°45'36" E for 30.00 feet; thence run S 88°14'19" W for 70.90 feet to the Point of Beginning.

Parcel IV:

Easements as granted by Declaration of Covenants, Conditions and Restrictions recorded September 21, 2000 in Official Records Book 30868, page 0811, Public Records of Broward County, Florida.

Parcel V:

Non Exclusive Easements for signage as granted by and described in SIGNAGE EASEMENT AGREEMENT recorded in Official Records Book 27734, page 477, as amended by AMENDED SIGNAGE EASEMENT AGREEMENT recorded September 21, 2000 in Official Records Book 30868, page 893, Public Records of Broward County, Florida.

Parcel VI:

Non Exclusive Easements for signage as granted by and described in SIGNAGE EASEMENT AGREEMENT recorded in Official Records Book 27734, page 488, as amended by AMENDED AND RESTATED SIGNAGE EASEMENT AGREEMENT recorded September 21, 2000 in Official Records Book 30868, page 864, Public Records of Broward County, Florida.

Exhibit "B"
Legal Description – Grantee's Parcel

A portion of Parcel A of the Plat of "Coquina Flats" as recorded in Plat book 155, Page 29 of the Public Records of Broward County, Florida, being more particularly described as follows:

Commence at the Northwest corner of the Southwest one-quarter of Section 4, Township 51 South, Range 40 East; thence South 01 degree 42 minutes 28 seconds East along the West line of said Southwest one-quarter, a distance of 1572.30 feet; thence North 88 degrees 17 minutes 32 seconds East a distance of 61.04 feet to the point of beginning; thence continue North 88 degrees 17 minutes 32 seconds East a distance of 173.98 feet; thence South 01 degree 45 minutes 42 seconds East a distance of 278.66 feet; thence South 88 degrees 17 minutes 32 seconds West a distance of 178.27 feet to a point on the East right-of-way line of Dykes Road, according to said plat; thence North 09 degrees 36 minutes 07 seconds East a distance of 61.19 feet; thence North 01 degrees 42 minutes 28 seconds West a distance of 100.00 feet; thence North 20 degrees 08 minutes 34 seconds West a distance of 37.95 feet; thence North 01 degrees 42 minutes 28 seconds West a distance of 49.00 feet; thence North 05 degrees 08 minutes 06 seconds East a distance of 33.89 feet to the point of beginning; (the preceding five courses being coincident with said East right-of-way line)

Exhibit "C"
Parking Parcel

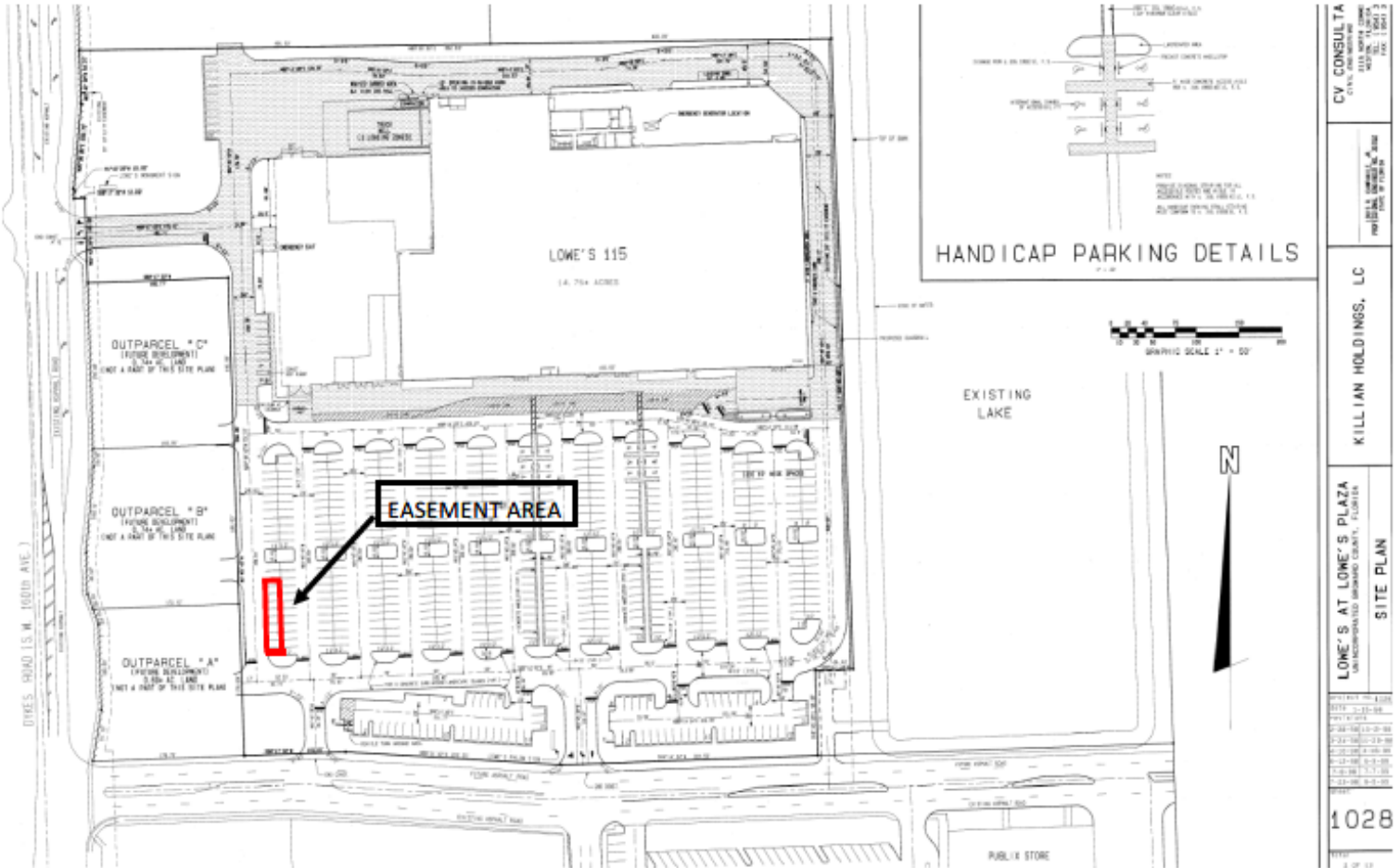

SURVEY MAP

SCALE: 1" = 20'

Point of Commencement—the Northwest corner of the Southwest Quarter, Township 51 South, Range 40 East

6670 DYKES ROAD, SOUTHWEST RANCHES, FLORIDA 33331
 National Flood Insurance Community Panel: 12011C0540H
 Flood Zone: AH
 Base Flood Elevation: 6'
 Firm Date: 8/18/2014

Certified to: SW RANCHES 6670 LLC
 Survey Date: 06/10/2024
 Job Number: 24-2097
 Revision:



Property Location

Legal Description:
 A certain portion of the premises [see sample], of the plot of "Coquina Flats" as recorded in Plat Book 155, Page 29 of the public records of Broward County, Florida, being more particularly described as follows: Commence at the Northwest corner of the Southwest one-quarter, Township 51 South, Range 40 East; thence South 01 degrees 42 minutes 28 seconds East a distance of 61.04 feet to the point of beginning; thence continue North 88 degrees 17 minutes 32 seconds East a distance of 173.98 feet; thence South 01 degrees 45 minutes 07 seconds East a distance of 178.27 feet to a point on the East right-of-way line of Dykes Road; thence North 09 degrees 36 minutes 07 seconds East a distance of 61.19 feet; thence North 01 degrees 28 seconds West a distance of 100.00 feet; thence North 20 degrees 08 minutes 34 seconds West a distance of 37.95 feet; thence North 01 degrees 42 minutes 28 seconds West a distance of 49.00 feet; thence North 05 degrees 08 minutes 06 seconds East a distance of 33.89 feet to the point of beginning; (the preceding five courses being coincident with said East right-of-way line)

Parcel 2 (Easement):
 together with those easements for ingress and egress as referenced in Article No. 6, and easements for site utilities as referenced in Article No. 7 of the Declaration of Condominium, and those easements for ingress and egress as referenced in Article No. 8 of that Declaration of Condominium, all as recorded in Official Records Book 28620, Page 279, and amended in Official Records Book 28852, Page 817 and Official Records Book 30833, Page 1640, of the public records of Broward County, Florida.

Parcel 3 (Easement):
 And together with those easements for permanent drives as referenced in Section 2.2 and easements for utility facilities as referenced in Section 2.3 of that certain declaration of covenants, conditions and restrictions recorded in Official Records Book 28620, Page 279, of the public records of Broward County, Florida.

Parcel 4 (Easement):
 Easement rights for the benefit of parcel 1 as created by that certain Access and Parking Easement Agreement recorded in Official Records Book 39381, Page 1929, of the public records of Broward County, Florida.

Commercial Building
 6670 Dykes Road
 Southwest Ranches, Florida
 Finished Floor: 7.66
 Footprint ±5,739.3 Sq. ft.

Point	Station	Date	Height	Comments
1	Top	14	18	24
2	Top	14	18	24
3	Top	10	18	24
4	Top	8	22	12
5	Top	8	22	12
6	Top	13	22	28
7	Top	8	18	8
8	Top	8	18	8
9	Top	10	22	10
10	Top	10	22	10
11	Top	10	22	10
12	Top	14	18	8
13	Top	14	18	8
14	Top	12	18	8
15	Top	12	18	8
16	Top	12	18	8
17	Top	8	18	8
18	Top	8	18	8
19	Top	10	22	10
20	Top	10	22	10
21	Top	10	22	10
22	Top	18	24	12
23	Top	18	24	12
24	Top	12	18	14
25	Top	12	18	14
26	Top	12	18	14
27	Top	14	24	12
28	Top	14	24	12
29	Top	16	20	12
30	Top	16	20	12
31	Top	13	22	12
32	Top	13	22	12
33	Top	10	24	10
34	Top	10	24	10
35	Top	16	20	12
36	Top	16	20	12
37	Top	14	24	12
38	Top	14	24	12
39	Top	14	24	12
40	Top	16	20	12
41	Top	16	20	12
42	Top	16	20	12
43	Top	6	18	8
44	Top	6	18	8
45	Top	12	22	12
46	Top	12	22	12
47	Top	14	22	18

SURVEYOR'S NOTES

- This is a topographic survey.
- This survey was provided by others.
- This survey has been prepared for the exclusive use of the entities named hereon and does not extend to any unnamed parties.
- The lands shown herein were not abstracted for easement or other recorded encumbrances not shown on the plat obtain current title work and verify easements before constructing improvements.
- This survey does not determine or imply ownership.
- This survey only shows above ground improvements, underground improvements, and utilities were not located.
- All dimensions and directions shown hereon are in substantial agreement with recorded plat and records in Broward County, Florida.
- Due to varying construction standards, house dimensions are approximate.
- All ties to property line are perpendicular to it, unless otherwise noted.
- In all cases dimensions shall control location over scaled positions.
- Elevations, if shown, are based on NAVD88, Benchmark F.D.O.T. N.T.R.I.P. stations (FLD & FLND).
- If there is a septic tank, well, or drain field marked on this survey, the location of such items was shown to us by others and the owner on 05/18/2024.
- Not valid without the signature & raised seal of a Florida licensed surveyor and mapper.
- I HEREBY CERTIFY THAT THE SURVEY REPRESENTED HEREON, AS RECENTLY SURVEYED AND DRAWN UNDER MY SUPERVISION, MEETS THE MINIMUM TECHNICAL STANDARDS AS SET FORTH IN CHAPTER 53-17 OF THE FLORIDA ADMINISTRATIVE CODE FOR THE BOARD OF PROFESSIONAL SURVEYORS AND MAPPERS PURSUANT TO SECTION 472.027 OF THE FLORIDA STATUTES.
- No part of this drawing may be reproduced by photocopying, recording or by any other means, or stored, processed or transmitted in or by any computer, or other systems without the prior written permission of R. Minguell Land Surveyors. Copies of this plan without an original signature and impression seal are not valid.

R. Minguell, Inc.
 Land Surveyors & Planners L.B.7272
 591 S.W. 112 Avenue
 Plantation, FL 33324
 954-298-8995
 R. Minguell
 R. Minguell@bellsouth.net

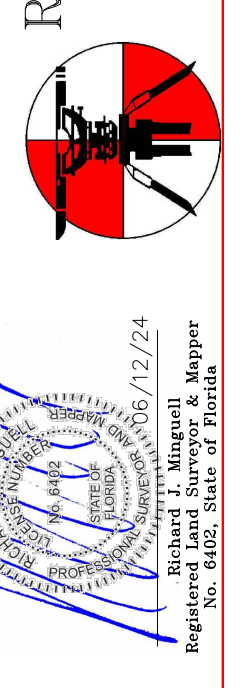

- ### LEGEND
- TELEPHONE MANHOLE
 - ELECTRIC METER
 - GAS METER
 - WATER METER
 - SINGLE TRAFFIC POLE
 - DUAL TRAFFIC POLE
 - UTILITY POLE
 - VALVE
 - CONTROL VALVE
 - FIRE MAIN VALVE
 - FORCE MAIN VALVE
 - GAS VALVE
 - SPRINKLER VALVE
 - WATER VALVE
 - MAIL BOX
 - CATCH BASIN
 - EXISTING ELEVATION
 - LIGHT POLE
 - UTILITY POLE
 - BENCHMARK
 - TRAFFIC FLOW/ACCESS
 - TRAFFIC SIGNAL BOX
 - BELLSOUTH BOX
 - CABLE BOX
 - ELECTRIC BOX
 - STREET LIGHT BOX
 - TELEPHONE BOX
 - ANCHOR
 - SEWER FLOW MONITOR
 - CLEAN OUT
 - WELL
 - WATER FLOW MONITOR
 - PARKING METER
 - FLAG POLE
 - BIKE SOLE
 - INTERSECTION SIGN
 - RAILROAD SIGN
 - SINGLE POLE SIGN
 - STOP SIGN
 - TRAFFIC SIGN
 - METAL POST
 - SPRINKLER TIMER
 - GUARD RAIL
 - HANDICAPPED PARKING
 - CHAIN LINK FENCE
 - WOOD FENCE
 - ALUMINUM FENCE
 - OVERHEAD WIRES
 - PROPERTY LINE
 - CENTER LINE
 - FIRE HYDRANT
 - MANHOLE
 - ELECTRIC MANHOLE
 - BELLSOUTH MANHOLE
 - DRAINAGE MANHOLE
 - GAS MANHOLE
 - STORM MANHOLE
 - SEWER MANHOLE
 - AIR CONDITIONER
 - POOL EQUIPMENT
 - NOT TO SCALE
 - BROWARD COUNTY RECORDS
 - PALM BEACH COUNTY RECORDS
 - MIAMI-DADE COUNTY RECORDS
 - FLORIDA POWER & LIGHT, CO TRANSFORMER
 - FLORIDA POWER & LIGHT, CO MANHOLE

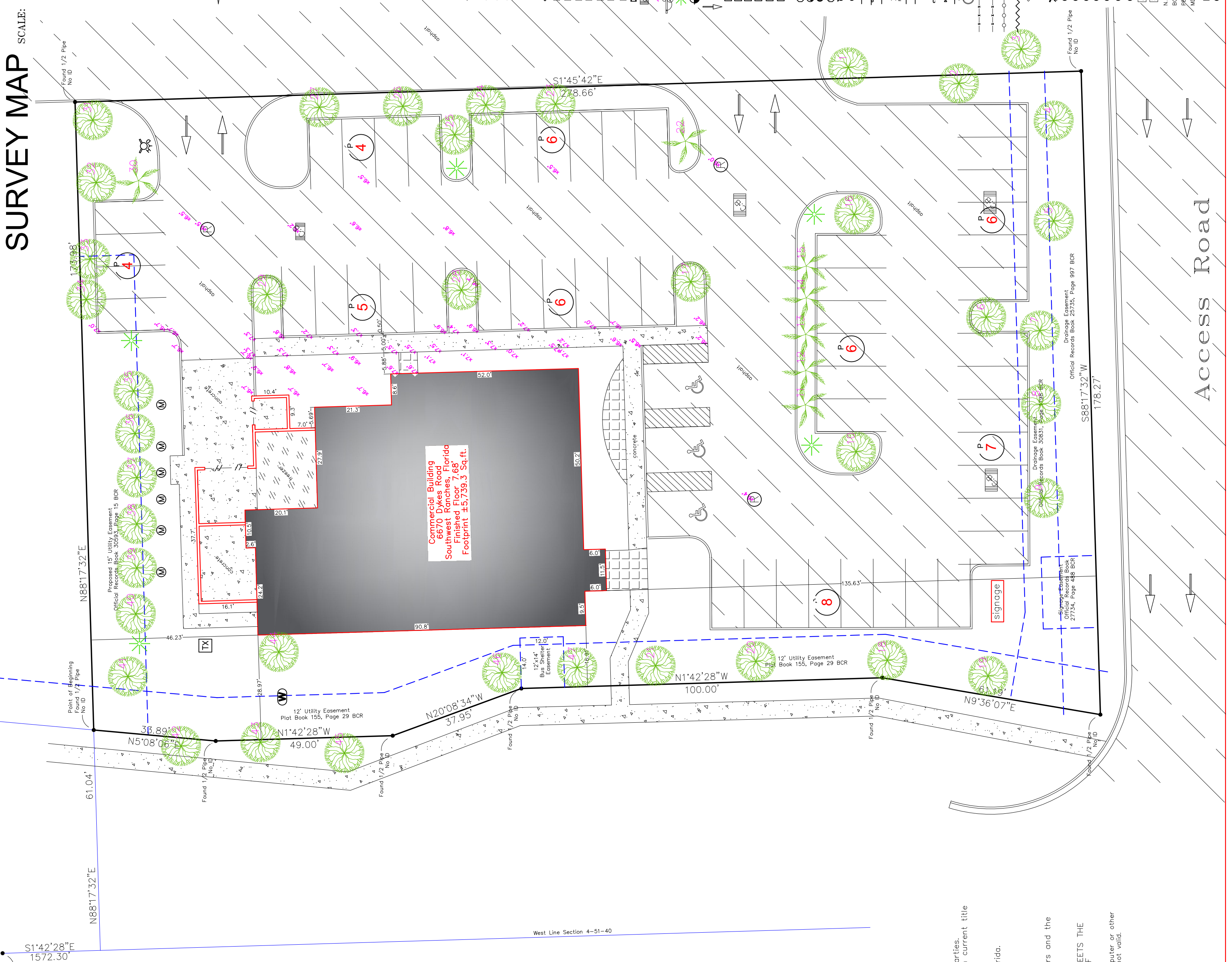

**This page
intentionally left blank**

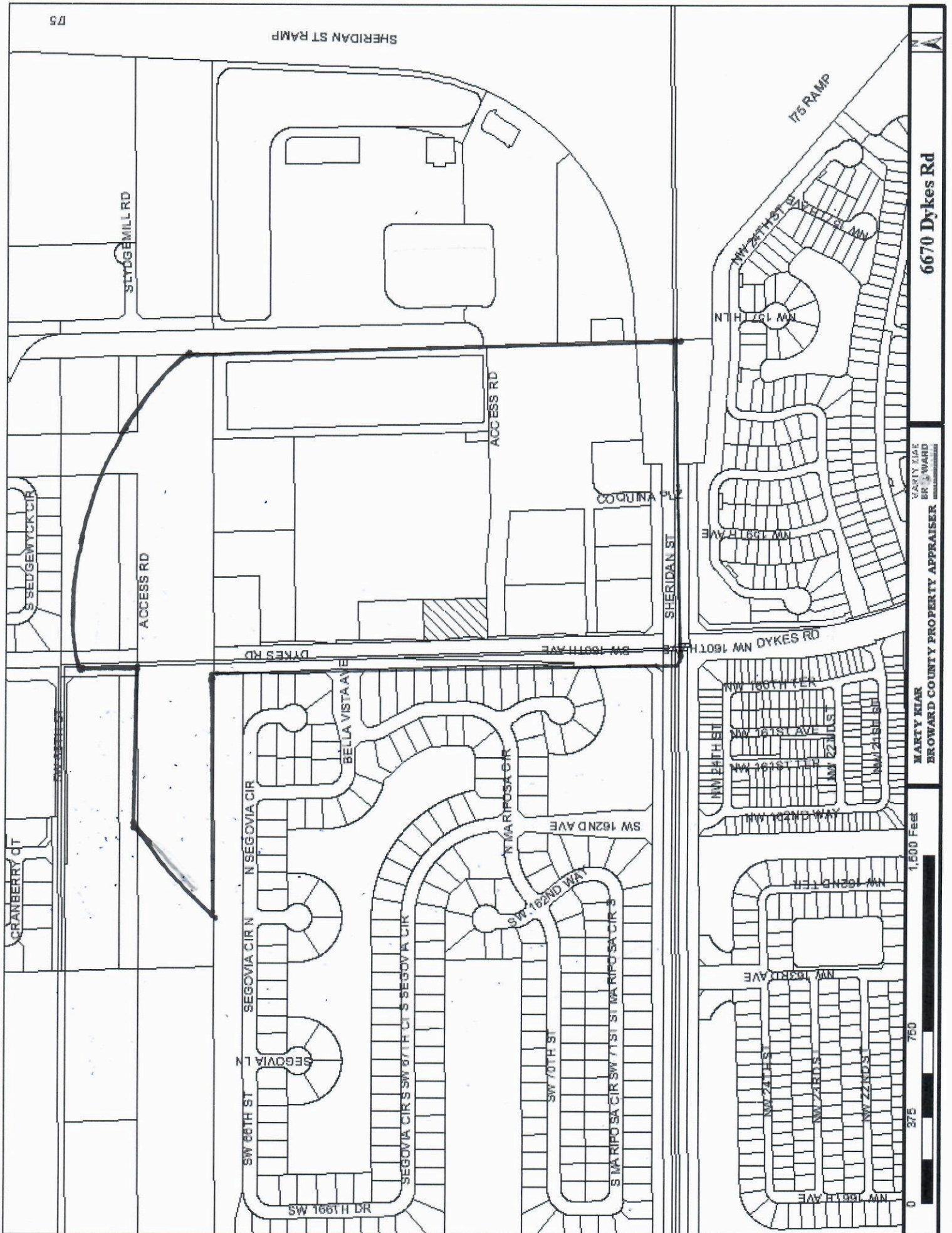

175

6670 Dykes Rd

MARTY KIAR
BROWARD COUNTY PROPERTY APPRAISER

1,500 Feet

**This page
intentionally left blank**

FOLIO_NUMB	NAME	ADDRESS_LI	CITY	STATE	ZIP	ZIP4	LEGAL
514004030110	R FARMS LAND LLC	6601 SW 160 AVE	SOUTHWEST RANCHES	FL	33331		CHAMBERS SUB SW 1/4 1-5B B4-51-40TRACT 11 S1/2 OF N1/2,TR 12E 180 OF N1/2 OF N1/2 & TR 12S1/2 OF N1/2,TR 14 LESS W 45.01
514004030020	COQUINA STATION LLC% PHILLIPS EDISON GROUP LLC	11501 NORTHLAKE DR	CINCINNATI	OH	45249		CHAMBERS SUB SW 1/4 1-5B B4-51-40TRACT 11 N1/2 OF N1/2 LESS S 80;TRACT 12 N1/2 OF N1/2 LESS S 80& LESS E 180 THEREOF & ALL OFTRACT 13 LESS W 55 FOR DYKES RD& LESS S 80AKA:WETLANDS MITIGATION AREA
514004030022	SOUTH BROWARD DRAINAGE DISTRICT	6591 SW 160 AVE	SOUTHWEST RANCHES	FL	33331		CHAMBERS SUB SW 1/4 1-5B BTRACT 11 S 80 OF N1/2 OF N1/2 &TRACT 12 S 80 OF N1/2 OF N1/2 OFTRACT 12 LESS E 180 THEREOF &TRACT 13 S 80 LESS W 55AKA:CANAL RIGHT OF WAY
514004100076	R FARMS LAND LLC	6601 SW 160 AVE	SOUTHWEST RANCHES	FL	33331		FLA FRUIT LANDS CO SUB NO 12-17 D 5-51-40TRACT 50
514004130022	COQUINA STATION LLC% PHILLIPS EDISON GROUP LLC	11501 NORTHLAKE DR	CINCINNATI	OH	45249		COQUINA FLATS 155-29 BPART OF PARCEL A DESC'D AS,BEGAT NE COR OF PARCEL A,S ALG E/L1182.07,WLY 372.50,NLY 1190.10TO PT ON N/L PARCEL A ELY 372.58TO POB,LESS PART DEEDED TO SOUTHBROWARD DRAINAGE DISTRICT INOR 30942/5AKA:LAKE BANK ADJ TO RETENTION AREA
514004130020	FLORIDA POWER & LIGHT COATTN PROPERTY TAX - PSX/JB	700 UNIVERSE BLVD	JUNO BEACH	FL	33408		COQUINA FLATS 155-29 BPART OF PARCEL A DESC'D AS,COMMAT NW COR OF PARCEL A,ELY ALGN/L 493.66 TO POB,CONT E 400.09,SLY 350.08,W 400.09,N 350.08 TOPOB
514004130015	CUBESMART LP	PO BOX 320099 PTA CS #721	ALEXANDRIA	VA	22320		COQUINA FLATS 155-29 BPART OF PARCEL A DESC'D AS,COMMAT NW COR OF PARCEL A,ELY ALGN/L FOR 302.46 TO POB,CONT ELYALG N/L FOR 191.20,SLY 350.08,WLY 481.97 TO E R/W/L OF DYKESROAD,NLY ALG SAME FOR 152.79,ELY290.64,NLY 197.29 TO POB
514004130013	RANCHES AUTO CARE & TIRE INC% BRIDGESTONE FIRESTONE/TAX	99 CORTE DEL BRISAS	MARATHON	FL	33050		COQUINA FLATS 155-29 BPART OF PARCEL A DESC'D AS,BEGAT NW COR OF PARCEL A,ELY ALGN/L FOR 302.46,SLY 197.29,WLY290.64,CONT WLY 12.00 TO PT ONE R/W/L OF DYKES ROAD,NLY ALGSAID E R/W/L FOR 197.53 TO POB
514004130023	SOUTH BROWARD DRAINAGE DISTRICT	6591 SW 160 AVE	SOUTHWEST RANCHES	FL	33331		COQUINA FLATS 155-29 BPART OF PARCEL A DESC'D AS,COMMAT NE COR OF PARCEL A,S 68.94,W40.00 TO POB,S 1087.53 TO P/C,SW15.71,W 272.50 TO P/C,NW 15.71,NLY 1093.43 TO P/C,NE 15.92,ELYALG LINE 60.00 S OF N/L PARCEL AFOR 272.56,SELY 15.49 TO POBAKA:MASTER STORM WATER RETENTIONAREA
514004130014	LOWES HOME CENTERS INC% TAX DEPT NB3TA	1000 LOWES BLVD	MOORESVILLE	NC	28117		COQUINA FLATS 155-29 BPOR OF PAR A DESC AS,COMMAT NW COR OF SW 1/4 OF SEC 4;SE ALG W/LOF SW1/4 A DIST OF 1572.30;NE61.04 TO POB NE 66.83;N 215;E 165.77;S 281.34;W 173.99 TOPOB
514004130012	SWR REALTY LLC	6650 DYKES RD	SOUTHWEST RANCHES	FL	33331		COQUINA FLATS 155-29 BPORTION OF PARCEL A DESC AS,COMMAT NW COR OF SW1/4 SEC 4 S ALGW/L FOR 1572.30 E 61.04 TO POB E 173.98,S 278.66,W 178.27,NE61.19,N 100,NW 37.95;N 49,NE33.89 TO POB
514004130017	SW RANCHES 6670 LLC	12391 PEMBROKE ROAD	PEMBROKE PINES	FL	33025		COQUINA FLATS 155-29 BPARCEL 'A' LESS PT DESC'D AS,COMMAT NW COR OF PARCEL A,E ALGN/L 493.66 TO POB,CONT E 400.09,SLY 350.08,W 400.09,N 350.08 TOPOB LESS PARTS K/A OUTPARCELS 2,3,5,6,7 & 8 & LESS PART DESC'D IN OR 28925/1892,OR 29865/602,OR 31278/1965 & OR 31570/1563 & OR 32994/1625 & LESS OR36500/281 & 39381/1876
514004130010	COQUINA STATION LLC% PHILLIPS EDISON GROUP LLC	11501 NORTHLAKE DR	CINCINNATI	OH	45249		

514004130080	MGT SOUTHWEST RANCHES LLC% REAL ESTE PROPERTY TAX	PO BOX 1159	DEERFIELD	IL	60015	COQUINA FLATS 155-29 BPOR PAR A DESC AS COMM AT MOSTSW COR PAR A,NW 38.78,NE 40.34,N217,W 12,N 12.04,NE 100.55,N61.96 TO POB,CONT N 76.52,N100.52,E 217.79,S 354.04,W212.79,N 3.04,W 12,N 12.64,NE 100.55,N 61.96 TO POBAKA:OUT PARCELS 7 & 8
514004130060	COQUINA STATION LLC% PHILLIPS EDISON GROUP LLC	11501 NORTHLAKE DR	CINNINNATI	OH	45249	COQUINA FLATS 155-29 BPART OF PARCEL A DESC'D AS:COMMAT MOST SLY SW COR OF PARCEL A,NW ALG W/L 38.78 TO E,RW/L OFDYKES RD,NLY 40.34,NLY 213.95,ELY 212.79 TO POB,NLY 354.04,ELY 320.47,S LY 323.25,WLY 319.66 TOPOBAKA:OUT PARCEL 6
514004130021	MG SOUTHWEST RANCHES LLC	3301 NE 1 AVE #109	MIAMI	FL	33137	COQUINA FLATS 155-29 BPOR PAR A DESC AS COMM MOST SLYSW COR OF SAID PAR A,E 575.79 TOPOB N 101.16,NW 93.57,NELY ARCDIST 82.14,E 177.79,S 216.20,W 102.67,S 30,W 119.84 TO POBAKA:OUT PARCEL 2
514004130030	MCDONALD'S CORPORATION% NCB INC	7301 SW 57 CT STE 520	MIAMI	FL	33143	COQUINA FLATS 155-29 BPOR PAR A DESC AS COMM MOST SLYSW COR OF SAID PAR A,E 350.32 TOPOB N 244.01 ,E 158.36,SE 148.93S 98.46,W 165.47 TO POBAKA:OUT PARCEL 3
514004130016	ALMAR DEVELOPMENT LLC	12200 NW 7 ST	PLANTATION	FL	33325	COQUINA FLATS 155-29 BPORTION OF PARCEL A DESC AS:COMMOST SLY SW COR PAR A,E 203.86ALG SIL PAR A TO POB,N 241.40,E144.58,S 244.01,W 146.46 TO POB
514004130050	SE PETRO ONE LLC	6867 SOUTHPOINT DR N STE 101	JACKSONVILLE	FL	32216	COQUINA FLATS 155-29 BPOR PAR A DESC AS:BEG AT MOSTSLY SW COR SAID PAR A;NW 38.87TO E LINE OF DYKES RD;NE 40.34,NW 170;E 226.20,S 241.40,W203.86 TO POBAKA:OUT PARCEL 5
514004130011	COQUINA STATION LLC% PHILLIPS EDISON GROUP LLC	11501 NORTHLAKE DR	CINNINNATI	OH	45249	COQUINA FLATS 155-29 BPART OF PARCEL A DESC'D AS,BEGAT SE COR OF PARCEL A,W 430.06,N216.20,WLY 177.79 TO P/C,SWLY82.14,S LY 93.57,S 101.16,W 60.00N 98.46,NLY 148.93,WLY 529.14 TOPT ON W/L,N 44.00,ELY 532.46,NLY323.25,W 320.47,WLY 217.79 TO PTON W/L,NLY 75.98,ELY 284.93,SELY253.20,ELY 718.18 TO PT ON E/LOF PARCEL A,S ALG E/L 649.63 TOPOB

January 23, 2025 Regular Meeting



Town of Southwest Ranches
13400 Griffin Road
Southwest Ranches, FL 33330-
2628

(954) 434-0008 Town Hall
(954) 434-1490 Fax

Town Council
Steve Breitreuz, Mayor
Bob Hartmann, Vice Mayor
Jim Allbritton, Council Member
Gary Jablonski, Council Member
David S. Kuczenski, Esq., Council Member

Russell C. Muniz, MBA, MPA, Town Administrator
Keith M. Poliakoff, JD, Town Attorney
Debra M. Ruesga, Town Clerk
Emil C. Lopez, CPM, Town Financial Administrator

COUNCIL MEMORANDUM

TO: Honorable Mayor Breitreuz and Town Council
VIA: Russell C. Muñiz, Town Administrator
FROM: Keith Poliakoff, Town Attorney
DATE: 1/23/2025
SUBJECT: Canine Minimum Interior Space Requirement

Recommendation

Town Council consideration to approve this ordinance on second reading.

Unanimous Vote of the Town Council Required?

No

Strategic Priorities

A. Sound Governance

Background

As a result of the State of Florida's Homebased Business Statute, Section 559.955, some residents have created homebased businesses relating to the care of canines; and such businesses include, but are not limited to, grooming, breeding, training and boarding canines.

While some organizations, including the American Kennel Club ("AKC") and the American Society for Prevention of Cruelty to Animals ("ASPCA"), recommend 100 square feet per canine, other organizations, including the Animal and Plant Health Inspection Service, have a less stringent standard and after reviewing the various agency recommendations and standards, the Town believes that a minimum interior space of 60 square feet per canine should be required to maintain canines within the Town.

All homebased businesses that maintain canines, are required to have a Certificate of Use,

and shall be subject to this minimum interior space requirement and all new Certificate of Uses issued for any homebased business relating to the maintenance of canines shall require a space plan showing the square footage of the canine use, that such square footage is not the primary use of the residence, the maximum number of canines being maintained, and that the Town is authorized to inspect the residence to ensure compliance with same. All homebased businesses shall be in strict accordance with Section 559.955 of the Florida Statutes, as may be amended from time to time.

The ability to regulate the space necessary to maintain canines is a permitted police power and the Town finds that this Code provision serves and addresses an important governmental interest, in a fair and constitutional manner, and that the adoption of this Ordinance is in the best interest of the public health, comfort, safety, and welfare. The Town has the power and authority to enact this Ordinance under State Law, the Florida Constitution, as well as controlling case law of the State of Florida.

Fiscal Impact/Analysis

N/A

Staff Contact:

Russell Muniz, Town Administrator
Keith Poliakoff, Town Attorney

ATTACHMENTS:

Description	Upload Date	Type
Business Impact Statement	12/6/2024	Resolution
Ordinance Second Reading	1/16/2025	Ordinance

Town of Southwest Ranches Business Impact Estimate Form



*This Business Impact Estimate Form is provided in accordance with **Section 166.041(4), Florida Statutes** and must be included in the agenda item backup for each proposed ordinance on first reading. A Business Impact Estimate Form must be prepared and posted on the Town's website for each ordinance by the date that the notice of the proposed ordinance is published, regardless of whether the ordinance is exempted under Section A below. This Business Impact Estimate Form may be revised following its initial posting.*

Title of proposed ordinance:

AN ORDINANCE OF THE TOWN OF SOUTHWEST RANCHES, FLORIDA, ESTABLISHING A MINIMUM INTERIOR SPACE REQUIREMENT TO MAINTAIN CANINES WITHIN THE TOWN; PROVIDING FOR INSPECTION; PROVIDING FOR SEVERABILITY AND PROVIDING AN EFFECTIVE DATE.

The provisions contained in this Section A constitute exemptions as provided in Section 166.041(4)(c). If one or more boxes are checked in Section A below, a business impact estimate is not required by state law for the proposed ordinance.

Section A

- The proposed ordinance is required for compliance with Federal or State law or regulation;
 - The proposed ordinance relates to the issuance or refinancing of debt;
 - The proposed ordinance relates to the adoption of budgets or budget amendments, including revenue sources necessary to fund the budget;
 - The proposed ordinance is required to implement a contract or an agreement, including, but not limited to, any Federal, State, local, or private grant or other financial assistance accepted by the Town;
 - The proposed ordinance is an emergency ordinance;
 - The proposed ordinance relates to procurement; or
- The proposed ordinance is enacted to implement the following:
- Development orders and development permits, as defined in s. 163.3164, and development agreements, as authorized by the Florida Local Government Development Agreement Act under ss. 163.3220-163.3243;
 - Comprehensive plan amendments and land development regulation amendments initiated by an application by a private party other than the Town;
 - Sections 190.005 and 190.046;
 - Section 553.73, Florida Statutes, relating to the Florida Building Code; or
 - Section 633.202, Florida Statutes, relating to the Florida Fire Prevention Code.

If an exemption in Section A is applicable, then only Section A needs to be completed. If there is no exemption in Section A, Section B must be completed.

Section B This section with the business impact estimate must be completed if the proposed ordinance does not meet any of the exemptions in Section A.

1. A summary of the proposed ordinance which must include a statement of the public purpose (e.g., public health, safety, morals and welfare).

The proposed ordinance is intended to provide a standard metric to apply to all dog businesses that seek to operate within the Town of Southwest Ranches. Establishing this standard ensures that neighborhoods are not negatively impacted by a proliferation of dog related businesses.

2. An estimate of the direct economic impact of the proposed ordinance on private, for-profit businesses in the Town, if any:

(a) An estimate of direct compliance costs that businesses may reasonably incur.

With 60 square feet of space per dog, businesses will be limited on the number of dogs that can be located at a property at one time. Once established, compliance costs would be minimal. No existing business, with a valid and current Certificate of Use, will be subject to or impacted by this Ordinance.

(b) Any new charge or fee on businesses subject to the proposed ordinance, or for which businesses will be financially responsible; and

N/A

(c) An estimate of the Town's regulatory costs, including an estimate of revenues from any new charges or fees to cover such costs.

N/A

3. Good faith estimate of the number of businesses likely to be impacted by the proposed ordinance:

5-10 businesses

4. Additional information/methodology for preparation, if any:

N/A

ORDINANCE NO. 2025-XXX

AN ORDINANCE OF THE TOWN OF SOUTHWEST RANCHES, FLORIDA, ESTABLISHING A MINIMUM INTERIOR SPACE REQUIREMENT TO MAINTAIN CANINES WITHIN THE TOWN; PROVIDING FOR INSPECTION; PROVIDING FOR SEVERABILITY AND PROVIDING AN EFFECTIVE DATE.

WHEREAS, as a result of the State of Florida’s Homebased Business Statute, Section 559.955, some residents have created homebased businesses relating to the care of canines; and

WHEREAS, such businesses include, but are not limited to, grooming, breeding, training and boarding canines; and

WHEREAS, while some organizations, including the American Kennel Club (“AKC”) and the American Society for Prevention of Cruelty to Animals (“ASPCA”), recommend 100 square feet per canine, other organizations, including the Animal and Plant Health Inspection Service, have a less stringent standard; and

WHEREAS, after reviewing the various agency recommendations and standards, the Town believes that a minimum interior space of 60 square feet per canine should be required to maintain canines within the Town; and

WHEREAS, all homebased businesses that maintain canines, are required to have a Certificate of Use, and shall be subject to this minimum interior space requirement; and

WHEREAS, all new Certificate of Uses issued for any homebased business relating to the maintenance of canines shall require a space plan showing the square footage of the canine use, that such square footage is not the primary use of the residence, the maximum number of canines being maintained, and that the Town is authorized to inspect the residence to ensure compliance with same; and

WHEREAS, all homebased businesses shall be in strict accordance with Section 559.955 of the Florida Statutes, as may be amended from time to time; and

WHEREAS, the ability to regulate the space necessary to maintain canines is a permitted police power; and

WHEREAS, the Town finds that this Code provision serves and addresses an important governmental interest, in a fair and constitutional manner, and that the adoption of this Ordinance is in the best interest of the public health, comfort, safety,

and welfare; and

WHEREAS, the Town has the power and authority to enact this Ordinance under State Law, the Florida Constitution, as well as controlling case law of the State of Florida.

NOW, THEREFORE, BE IT ENACTED BY THE TOWN COUNCIL OF THE TOWN OF SOUTHWEST RANCHES, FLORIDA:

SECTION 1. Recitals. The above recitals are true, correct and incorporated herein by reference.

SECTION 2. A section of the Town Code of Ordinances shall be created entitled "Maintenance of Canines" as follows:

- *Maintenance of Canines.*

- (1) All homebased businesses that maintain canines shall be required to have a minimum interior space of 60 square feet per canine; and
- (2) All homebased businesses that maintain canines shall be required to obtain a Certificate of Use; and
- (3) All residents seeking a Certificate of Uses for homebased businesses that maintain canines shall provide a space plan showing the square footage of the canine use, that such square footage is not the primary use of the residence, the maximum number of canines being maintained, and that the Town is authorized to inspect the residence to ensure compliance with the Certificate of Use at anytime; and
- (4) If a request for an inspection is ever denied, the Town may immediately commence the procedures set forth in Sec. 005-120(C), in order to revoke the Certificate of Use; and
- (5) All homebased businesses shall be maintained in strict accordance with Section 559.955 of the Florida Statutes, as may be amended from time to time.

SECTION 3. Severability. Should any section or provision of this Ordinance or any portion thereof, any paragraph, sentence or word hereof be declared unconstitutional or invalid, the invalidity thereof shall not affect the validity of any of the remaining portions of this Ordinance.

SECTION 4. Effective Date. This Ordinance shall take effect immediately upon its Passage and adoption.

PASSED ON FIRST READING this 12th day of December, 2024 on a motion made by Council Member Jablonski and seconded by Vice Mayor Hartmann.

PASSED ON SECOND READING this ___ day of ___,2024 on a motion made by _____ and seconded by _____.

Breitkreuz _____
Hartmann _____
Allbritton _____
Jablonski _____
Kuczenski _____

Ayes _____
Nays _____
Absent _____
Abstaining _____

Steve Breitkreuz, Mayor

Attest:

Debra M. Ruesga, Town Clerk

Approved as to Form and Correctness:

Keith Poliakoff, Town Attorney
1001.111.2024

**This page
intentionally left blank**



Town of Southwest Ranches
13400 Griffin Road
Southwest Ranches, FL 33330-
2628

(954) 434-0008 Town Hall
(954) 434-1490 Fax

Town Council
Steve Breitreuz, Mayor
Bob Hartmann, Vice Mayor
Jim Allbritton, Council Member
Gary Jablonski, Council Member
David S. Kuczenski, Esq., Council Member

Russell C. Muniz, MBA, MPA, Town Administrator
Keith M. Poliakoff, JD, Town Attorney
Debra M. Ruesga, Town Clerk
Emil C. Lopez, CPM, Town Financial Administrator

COUNCIL MEMORANDUM

TO: Honorable Mayor Breitreuz and Town Council
VIA: Russell Muniz, Town Administrator, ICMA-CM
FROM: Kathryn Sims, Deputy Town Administrator
DATE: 1/23/2025
SUBJECT: Adoption of Public Sleeping and Camping legislation in compliance with State Law

Recommendation

Staff recommends the approval of the proposed ordinance on second reading.

Unanimous Vote of the Town Council Required?

No

Strategic Priorities

- A. Sound Governance
- C. Reliable Public Safety

Background

During its 2024 legislative session the Florida Legislature enacted House Bill 1365, which prohibits counties or municipalities from authorizing or otherwise allowing “any person to regularly engage in public camping or sleeping on any public property, including, but not limited to, any public building or its grounds and any public right-of-way under the jurisdiction of the county or municipality, as applicable”. House Bill 1365 was codified as Section 125.0231, Florida Statutes, became effective July 1, 2024 and prohibits counties or municipalities from authorizing or otherwise allowing any person to regularly engage in public camping or sleeping on any public property, including, but not limited to, any public building or its grounds and any public right-of-way under the jurisdiction of the county or municipality, as applicable”.

Additionally, the House Bill 1365 creates a private cause of action, that becomes effective on January 1, 2025, which provides the authority for a resident to sue a municipality for damages and attorney fees if, after five business days' notice to the municipality of a violation of Section 123.0231, the violation has not been cured by the municipality. The Town of Southwest Ranches contracts its public safety responsibility to the Town of Davie, Florida, and through the contractual obligation the Town of Davie has full authority to enforce this Ordinance within the jurisdictional boundaries of the Town of Southwest Ranches. For consistency across the jurisdictional boundaries adopting similar law as the Town of Davie, in regard to FSS Section 125.0231, is in the best interest of and will reasonably protect the health, safety, and welfare of the Town's residents. This Ordinance creates a process for notification or complaints by any person, business owner, or the Florida Attorney General, through the development of an email address which must be easily accessible to the Town's residents and located on the Town's website. Certain information is required by the complainant in order for the Town to take reasonable action and to cure the violation withing the statutory five (5) day period.

Fiscal Impact/Analysis

None.

Staff Contact:

Russell Muniz, Town Administrator, ICMA-CM

Kathryn Sims, Deputy Town Administrator

ATTACHMENTS:

Description	Upload Date	Type
Business Impact Statement	12/5/2024	Backup Material
Ordinance - 2nd Reading	1/16/2025	Ordinance

Town of Southwest Ranches Business Impact Estimate Form



*This Business Impact Estimate Form is provided in accordance with **Section 166.041(4), Florida Statutes** and must be included in the agenda item backup for each proposed ordinance on first reading. A Business Impact Estimate Form must be prepared and posted on the Town's website for each ordinance by the date that the notice of the proposed ordinance is published, regardless of whether the ordinance is exempted under Section A below. This Business Impact Estimate Form may be revised following its initial posting.*

Title of proposed ordinance:

AN ORDINANCE OF THE TOWN OF SOUTHWEST RANCHES, FLORIDA; CREATING CHAPTER 28 OF THE TOWN OF SOUTHWEST RANCHES CODE OF ORDINANCES, TO CREATE A CHAPTER ENTITLED PUBLIC CAMPING OR SLEEPING; PROHIBITION; PENALTIES; COMPLAINTS; PROVIDING FOR SEVERABILITY, PROVIDING FOR CODIFICATION, AND PROVIDING AN EFFECTIVE DATE.

The provisions contained in this Section A constitute exemptions as provided in Section 166.041(4)(c). If one or more boxes are checked in Section A below, a business impact estimate is not required by state law for the proposed ordinance.

Section A

- The proposed ordinance is required for compliance with Federal or State law or regulation;
 - The proposed ordinance relates to the issuance or refinancing of debt;
 - The proposed ordinance relates to the adoption of budgets or budget amendments, including revenue sources necessary to fund the budget;
 - The proposed ordinance is required to implement a contract or an agreement, including, but not limited to, any Federal, State, local, or private grant or other financial assistance accepted by the Town;
 - The proposed ordinance is an emergency ordinance;
 - The proposed ordinance relates to procurement; or
- The proposed ordinance is enacted to implement the following:
- Development orders and development permits, as defined in s. 163.3164, and development agreements, as authorized by the Florida Local Government Development Agreement Act under ss. 163.3220-163.3243;
 - Comprehensive plan amendments and land development regulation amendments initiated by an application by a private party other than the Town;
 - Sections 190.005 and 190.046;
 - Section 553.73, Florida Statutes, relating to the Florida Building Code; or
 - Section 633.202, Florida Statutes, relating to the Florida Fire Prevention Code.

If an exemption in Section A is applicable, then only Section A needs to be completed. If there is no exemption in Section A, Section B must be completed.

Section B This section with the business impact estimate must be completed if the proposed ordinance does not meet any of the exemptions in Section A.

1. A summary of the proposed ordinance which must include a statement of the public purpose (e.g., public health, safety, morals and welfare).

2. An estimate of the direct economic impact of the proposed ordinance on private, for-profit businesses in the Town, if any:

(a) An estimate of direct compliance costs that businesses may reasonably incur.

(b) Any new charge or fee on businesses subject to the proposed ordinance, or for which businesses will be financially responsible; and

(c) An estimate of the Town's regulatory costs, including an estimate of revenues from any new charges or fees to cover such costs.

3. Good faith estimate of the number of businesses likely to be impacted by the proposed ordinance:

4. Additional information/methodology for preparation, if any:

ORDINANCE NO. 2025-XXX

AN ORDINANCE OF THE TOWN OF SOUTHWEST RANCHES, FLORIDA; CREATING CHAPTER 28 OF THE TOWN OF SOUTHWEST RANCHES CODE OF ORDINANCES, TO CREATE A CHAPTER ENTITLED PUBLIC CAMPING OR SLEEPING; PROHIBITION; PENALTIES; COMPLAINTS; PROVIDING FOR SEVERABILITY, PROVIDING FOR CODIFICATION, AND PROVIDING AN EFFECTIVE DATE.

WHEREAS, it is the policy of the Town of Southwest Ranches that public property, such as streets and parks should be readily accessible and available for use by Town residents for their safe enjoyment; and

WHEREAS, the use of public areas by individuals for camping interferes with the rights of residents and the public to freely use public spaces for the purpose for which they were intended; and

WHEREAS, during its 2024 legislative session the Florida Legislature enacted House Bill 1365, which prohibits counties or municipalities from authorizing or otherwise allowing “any person to regularly engage in public camping or sleeping on any public property, including, but not limited to, any public building or its grounds and any public right-of-way under the jurisdiction of the county or municipality, as applicable”; and

WHEREAS, House Bill 1365 was codified as Section 125.0231, Florida Statutes, became effective July 1, 2024 and prohibits counties or municipalities from authorizing or otherwise allowing any person to regularly engage in public camping or sleeping on any public property, including, but not limited to, any public building or its grounds and any public right-of-way under the jurisdiction of the county or municipality, as applicable”; and

WHEREAS, additionally, the House Bill 1365 creates a private cause of action, that becomes effective on January 1, 2025, which provides the authority for a resident to sue a municipality for damages and attorney fees if, after five business days’ notice to the municipality of a violation of Section 123.0231, the violation has not been cured by the municipality; and

WHEREAS, the Town of Southwest Ranches contracts its public safety responsibility to the Town of Davie, Florida, and through the contractual obligation the Town of Davie has full authority to enforce this Ordinance within the jurisdictional boundaries of the Town of Southwest Ranches; and

WHEREAS, for consistency across the jurisdictional boundaries of the Town of Southwest Ranches and the Town of Davie, the Town Council finds adopting similar law in regard to Florida State Statute Section 125.0231 is in the best interest of and will reasonably protect the health, safety, and welfare of the Town’s residents.

NOW, THEREFORE, BE IT ENACTED BY THE TOWN COUNCIL OF THE TOWN OF SOUTHWEST RANCHES, FLORIDA:

SECTION 1. Recitals. The above recitals are true, correct and incorporated herein by reference.

SECTION 2. a new Chapter 28 of the Code of Ordinances of the Town is hereby created as follows:

Chapter 28. Public camping or sleeping; prohibition; penalties; complaints.

28.1 In accordance with Section 125.0231, Florida Statutes, it is the policy of the Town to not authorize or otherwise allow any person to regularly engage in public camping or sleeping, as subsequently defined, on any public property under the jurisdiction of the Town.

28.2 As used in this section, “public camping or sleeping” is to be construed in conformity with the meaning of “public camping or sleeping” set forth under Section 125.0231(1)(b), Florida Statutes.

- (1) “Public camping or sleeping” means:
 - a. Lodging or residing overnight in a temporary outdoor habitation used as a dwelling or living space and evidenced by the erection of a tent or other temporary shelter, the presence of bedding or pillows, or the storage of personal belongings; or
 - b. Lodging or residing overnight in an outdoor space without a tent or other temporary shelter.

- (2) “Public camping or sleeping” does not include:
 - a. Lodging or residing overnight in a motor vehicle that is registered, insured, and located in a place where it may lawfully be; or
 - b. Camping for recreational purposes on property designated for such purposes.

28.3 Violation.

- (1) No person may regularly engage in public camping or sleeping on any public property, including, but not limited to, any public building or its grounds and any public right-of-way under the jurisdiction of the Town.

28.4 Penalty.

- (1) Any person found in violation of this section shall be punished pursuant to Section 1-11 of the Town Code of Ordinances.

28.5 Complaints.

- (1) Any person, business owner, or the Florida Attorney General, may provide written notice of a violation of this Section to the Town.
- (2) The Town Administrator shall designate an e-mail address or other electronic submission method, to be displayed on the Town's website, to serve as the primary means of receiving such written notice.
- (3) To enable the Town to take reasonable action within the limits of its authority to cure an alleged violation, the written notice must specify:
 - a. The name and contact information of the complainant;
 - b. The location of the violation;
 - c. The date(s) of the alleged violation;
 - d. A description or photograph of the alleged violator; and
 - e. Any other information that will assist the Town to address or otherwise to cure the alleged violation.

SECTION 3. Severability. Should any section or provision of this Ordinance or any portion thereof, any paragraph, sentence or word hereof be declared unconstitutional or invalid, the invalidity thereof shall not affect the validity of any of the remaining portions of this Ordinance.

SECTION 4. Effective Date. This Ordinance shall take effect immediately upon its passage and adoption.

PASSED ON FIRST READING this 12th day of, December, 2024 on a motion made by Council Member Jablonski and seconded by Council Member Kuczenski.

PASSED ON SECOND READING this 23rd day of January, 2025 on a motion made by _____ and seconded by _____.

Breitkreuz _____
Hartmann _____
Allbritton _____
Jablonski _____
Kuczenski _____

Ayes _____
Nays _____
Absent _____
Abstaining _____

Steve Breitkreuz, Mayor

Attest:

Debra Ruesga, Town Clerk

Approved as to Form and Correctness:

Keith Poliakoff, Town Attorney
1001.106.2024



Town of Southwest Ranches
13400 Griffin Road
Southwest Ranches, FL 33330-
2628

(954) 434-0008 Town Hall
(954) 434-1490 Fax

Town Council
Steve Breitreuz, Mayor
Bob Hartmann, Vice Mayor
Jim Allbritton, Council Member
Gary Jablonski, Council Member
David S. Kuczenski, Esq., Council Member

Russell C. Muniz, MBA, MPA, Town Administrator
Keith M. Poliakoff, JD, Town Attorney
Debra M. Ruesga, Town Clerk
Emil C. Lopez, CPM, Town Financial Administrator

COUNCIL MEMORANDUM

TO: Honorable Mayor Breitreuz and Town Council
VIA: Russell Muniz, Town Administrator
FROM: Keith Poliakoff, Town Attorney
DATE: 1/23/2025
SUBJECT: Repeal and Replace Ordinance No. 2024-003

Recommendation

Town Council consideration for a motion to approve the ordinance on second reading.

Strategic Priorities

A. Sound Governance

Background

Pursuant to Ordinance 2020-006 adopted on July 9, 2020, the Town Council of the Town of Southwest Ranches created Chapter 9 of the Code of Ordinances, entitled "Noise" in order to establish standards for the acceptable levels of noise to protect the quiet enjoyment of the Town.

Within this newly created Chapter 9, Section 9-5 delineated several exemptions. One such exemption provides that noise emanating from non-farm animals are exempt provided that they do not constitute a nuisance, as defined by the Town's Code.

The term nuisance is not defined within Chapter 9 and as such, this provision has been difficult to enforce and to further address the issues and problems associated with non-farm animal noise, the Town finds that it is necessary and proper to amend its existing regulation.

The ability to regulate noise and prevent noise pollution is a permitted police power and Article II, Section 7, of the Florida Constitution provides that adequate provisions shall be

made by law for abatement of excessive and unnecessary noise. Providing for the quietude of residential and agricultural areas within the Town is an important governmental interest and in direct compliance with Article II, Section 7, of the Florida Constitution and the Town finds that this amendment serves and addresses an important governmental interest, in a fair and constitutional manner, and that the adoption of this Ordinance is in the best interest of the public health, comfort, safety, and welfare.

The ability to regulate noise, and to ensure and to protect all resident's quality of life, the Town Council finds that this amendment is in the best interest and will reasonably protect the Town and its residents and the Town has the power and authority to enact this Ordinance under State Law, the Florida Constitution, as well as controlling case law of the State of Florida.

Fiscal Impact/Analysis

N/A

Staff Contact:

Russell Muniz, Town Administrator
Keith Poliakoff, Town Attorney

ATTACHMENTS:

Description	Upload Date	Type
Business Impact Statement	12/6/2024	Backup Material
Ordinance Second Reading	1/16/2025	Ordinance

Town of Southwest Ranches Business Impact Estimate Form



*This Business Impact Estimate Form is provided in accordance with **Section 166.041(4), Florida Statutes** and must be included in the agenda item backup for each proposed ordinance on first reading. A Business Impact Estimate Form must be prepared and posted on the Town's website for each ordinance by the date that the notice of the proposed ordinance is published, regardless of whether the ordinance is exempted under Section A below. This Business Impact Estimate Form may be revised following its initial posting.*

Title of proposed ordinance:

AN ORDINANCE OF THE TOWN OF SOUTHWEST RANCHES, FLORIDA, REPEALING AND REPLACING ORDINANCE NO. 2024-003; AMENDING SECTION 9-5 OF CHAPTER 9 ENTITLED "NOISE" OF THE TOWN OF SOUTHWEST RANCHES CODE OF ORDINANCES, TO AMEND THE LIST OF EXEMPTIONS; PROVIDING FOR SEVERABILITY AND PROVIDING AN EFFECTIVE DATE.

The provisions contained in this Section A constitute exemptions as provided in Section 166.041(4)(c). If one or more boxes are checked in Section A below, a business impact estimate is not required by state law for the proposed ordinance.

Section A

- The proposed ordinance is required for compliance with Federal or State law or regulation;
 - The proposed ordinance relates to the issuance or refinancing of debt;
 - The proposed ordinance relates to the adoption of budgets or budget amendments, including revenue sources necessary to fund the budget;
 - The proposed ordinance is required to implement a contract or an agreement, including, but not limited to, any Federal, State, local, or private grant or other financial assistance accepted by the Town;
 - The proposed ordinance is an emergency ordinance;
 - The proposed ordinance relates to procurement; or
- The proposed ordinance is enacted to implement the following:
- Development orders and development permits, as defined in s. 163.3164, and development agreements, as authorized by the Florida Local Government Development Agreement Act under ss. 163.3220-163.3243;
 - Comprehensive plan amendments and land development regulation amendments initiated by an application by a private party other than the Town;
 - Sections 190.005 and 190.046;
 - Section 553.73, Florida Statutes, relating to the Florida Building Code; or
 - Section 633.202, Florida Statutes, relating to the Florida Fire Prevention Code.

If an exemption in Section A is applicable, then only Section A needs to be completed. If there is no exemption in Section A, Section B must be completed.

Section B This section with the business impact estimate must be completed if the proposed ordinance does not meet any of the exemptions in Section A.

1. A summary of the proposed ordinance which must include a statement of the public purpose (e.g., public health, safety, morals and welfare).

This Ordinance removes an exemption from the Noise Ordinance that allowed non-farm animals an exemption from said ordinance, as long as they didn't create a nuisance. This language is nebulous, and the term nuisance wasn't clearly defined in the original code language. Removing this language ensures the public health of the community by ensuring that non-farm animals creating a disturbance may be cited.

2. An estimate of the direct economic impact of the proposed ordinance on private, for-profit businesses in the Town, if any:

(a) An estimate of direct compliance costs that businesses may reasonably incur.

Non-farm animal facilities will have to ensure that staff bring animals that are creating a disturbance outside, inside their facility. It will be difficult to estimate direct compliance as it will be based on the number of instances where non-farm animals cause a disturbance. This cost cannot be quantified.

(b) Any new charge or fee on businesses subject to the proposed ordinance, or for which businesses will be financially responsible; and

N/A

(c) An estimate of the Town's regulatory costs, including an estimate of revenues from any new charges or fees to cover such costs.

N/A

3. Good faith estimate of the number of businesses likely to be impacted by the proposed ordinance:

5-10 businesses

4. Additional information/methodology for preparation, if any:

N/A

ORDINANCE NO. 2025-XXX

AN ORDINANCE OF THE TOWN OF SOUTHWEST RANCHES, FLORIDA, REPEALING AND REPLACING ORDINANCE NO. 2024-003; AMENDING SECTION 9-5 OF CHAPTER 9 ENTITLED "NOISE" OF THE TOWN OF SOUTHWEST RANCHES CODE OF ORDINANCES, TO AMEND THE LIST OF EXEMPTIONS; PROVIDING FOR SEVERABILITY AND PROVIDING AN EFFECTIVE DATE.

WHEREAS, pursuant to Ordinance 2020-006 adopted on July 9, 2020, the Town Council of the Town of Southwest Ranches created Chapter 9 of the Code of Ordinances, entitled "Noise" in order to establish standards for the acceptable levels of noise to protect the quiet enjoyment of the Town; and

WHEREAS, within this newly created Chapter 9, Section 9-5 delineated several exemptions; and

WHEREAS, one such exemption provides that noise emanating from non-farm animals are exempt provided that they do not constitute a nuisance, as defined by the Town's Code; and

WHEREAS, the term nuisance is not defined within Chapter 9 and as such, this provision has been difficult to enforce; and

WHEREAS, to further address the issues and problems associated with non-farm animal noise, the Town finds that it is necessary and proper to amend its existing regulation; and

WHEREAS, the ability to regulate noise and prevent noise pollution is a permitted police power; and

WHEREAS, Article II, Section 7, of the Florida Constitution provides that adequate provisions shall be made by law for abatement of excessive and unnecessary noise; and

WHEREAS, providing for the quietude of residential and agricultural areas within the Town is an important governmental interest and in direct compliance with Article II, Section 7, of the Florida Constitution; and

WHEREAS, the Town finds that this amendment serves and addresses an important governmental interest, in a fair and constitutional manner, and that the adoption of this Ordinance is in the best interest of the public health, comfort, safety,

and welfare; and

WHEARAS, the ability regulate noise, and to ensure and to protect all resident's quality of life, the Town Council finds that this amendment is in the best interest and will reasonably protect the Town and its residents; and

WHEREAS, the Town has the power and authority to enact this Ordinance under State Law, the Florida Constitution, as well as controlling case law of the State of Florida.

NOW, THEREFORE, BE IT ENACTED BY THE TOWN COUNCIL OF THE TOWN OF SOUTHWEST RANCHES, FLORIDA:

SECTION 1. Recitals. The above recitals are true, correct and incorporated herein by reference.

SECTION 2. Repeal and Replace. Upon adoption, this Ordinance repeals and replaces Ordinance No. 2024-003, adopted on December 14, 2024.

SECTION 4. Amendment. Chapter 9, Section 9-5 "Exemptions" of the Code of Ordinances of the Town is hereby amended as follows:

Sec. 9-5. - **Exemptions.**

The provisions of section 9-3 shall not apply at any time to:

- (1) Motor vehicles legally operating on a public right-of-way;
- (2) The unamplified human voice;
- (3) Any noise generated by new products or interstate motor and rail carrier vehicles to the extent that local regulation of noise levels of such new products and interstate motor and rail carrier vehicles has been pre-empted by the Noise Control Act of 1972 (49 U. S. C. Section 4901 et seq.) or other applicable federal laws or regulations;
- (4) Farming equipment;
- (5) Any noise generated by the movement of aircraft in accordance with or pursuant to applicable federal laws or regulations;
- (6) Maintenance and installation of public service utilities;
- (7) Noise generated for the purpose of alerting persons to the existence of an

- emergency or noise generated in the performance of emergency work;
- (8) Any noise generated by any noncommercial public speaking and public assembly activities conducted on any public space or public right-of-way pursuant to lawful authority; and
 - (9) Any noise generated by the operation or testing of engines, landscaping equipment, generators, pumps, mechanical equipment, construction tools, emergency equipment or similar noises that are common to residential properties;
 - (10) Refuse collection;
 - (11) Construction in accordance with the construction hours set forth in the Town Code;
 - (12) Any noise generated on a Town owned property, which is authorized by the Town;
 - (13) Any noise generated by the Town or by a Town event;
 - (14) Farm animals;
 - (15) Home workshops in accordance with the construction hours set forth in the Town Code; and Any special event that has been approved by the Town.
 - (16) Any special event that has been approved by the Town.

SECTION 3. Severability. Should any section or provision of this Ordinance or any portion thereof, any paragraph, sentence or word hereof be declared unconstitutional or invalid, the invalidity thereof shall not affect the validity of any of the remaining portions of this Ordinance.

SECTION 4. Effective Date. This Ordinance shall take effect immediately upon its Passage and adoption.

PASSED ON FIRST READING this 12th day of December, 2024 on a motion made by Council Member Jablonski and seconded by Council Member Kuczenski.

PASSED ON SECOND READING this ___ day of ___,2024 on a motion made by _____ and seconded by _____.

Breitkreuz _____
Hartmann _____
Allbritton _____
Jablonski _____
Kuczenski _____

Ayes _____
Nays _____
Absent _____
Abstaining _____

Steve Breitkreuz, Mayor

Attest:

Debra M. Ruesga, Town Clerk

Approved as to Form and Correctness:

Keith Poliakoff, Town Attorney
1001.110.2024



Town of Southwest Ranches
13400 Griffin Road
Southwest Ranches, FL 33330-
2628

(954) 434-0008 Town Hall
(954) 434-1490 Fax

Town Council
Steve Breitreuz, Mayor
Bob Hartmann, Vice Mayor
Jim Allbritton, Council Member
Gary Jablonski, Council Member
David S. Kuczenski, Esq., Council Member

Russell C. Muniz, MBA, MPA, Town Administrator
Keith M. Poliakoff, JD, Town Attorney
Debra M. Ruesga, Town Clerk
Emil C. Lopez, CPM, Town Financial Administrator

COUNCIL MEMORANDUM

TO: Honorable Mayor Breitreuz and Town Council
VIA: Russell Muñiz, Town Administrator
FROM: Emil C. Lopez, Town Financial Administrator
DATE: 1/23/2025
SUBJECT: Investment Policy

Recommendation

It is recommended that the Town Council approves the accompanying resolution adopting the Town's investment policy.

Unanimous Vote of the Town Council Required?

No

Strategic Priorities

- A. Sound Governance
- B. Enhanced Resource Management

Background

In direct response to the investment crisis and reported investment losses by some local governments in Florida, the Florida Legislature passed and adopted in 1999, the requirements for investment policies known as the "Investment of Local Government Surplus Finds Act" and codified in Section 218.40, Florida Statutes (1999). Accordingly, Section 218.415, Florida Statutes, requires a local government to adopt written investment policies or to elect to proceed under Subsection 17 (218.415) which sets forth alternative investment guidelines.

On August 8th, 2000, the Town Council adopted resolution 2000-06 to utilize the alternative investment guidelines specified in Section 218.415(17), Florida Statutes. In the Town following these alternative investment guidelines (17), we have identified that it is in the best interest to

the Town to establish a written policy as it will provide an increased number of investments options while maintaining the highest priority on the safety of principal and liquidity of funds.

Fiscal Impact/Analysis

Adoption of this policy does not represent a cost to the Town. As per Section 218.401, Florida Statutes, it is the intent of this policy the maximization of net interest earnings on invested surplus by the Town of Southwest Ranches, based on the principles of investor protection, mandated transparency, and proper governance, with the goal of reducing the need of imposing additional taxes.

Staff Contact:

Emil C. Lopez, Town Financial Administrator

ATTACHMENTS:

Description	Upload Date	Type
Resolution - TA Approved	1/17/2025	Resolution
Exhibit "A" Investment Policy	1/17/2025	Exhibit
Attachment A - Investment Pool/Fund Questionnaire	1/15/2025	Exhibit

RESOLUTION NO. 2025-XXX

A RESOLUTION OF THE TOWN COUNCIL OF THE TOWN OF SOUTHWEST RANCHES, FLORIDA, ADOPTING THE INVESTMENT POLICY IN SUBSTANTIALLY THE SAME FORM AS ATTACHED HERETO AS EXHIBIT "A"; PROVIDING FOR SEVERABILITY; AND PROVIDING FOR AN EFFECTIVE DATE.

WHEREAS, the purpose of a fund balance policy is to serve as a framework for consistent operations and appropriate reporting as to non-spendable, restricted, committed, assigned, and unassigned fund balances to improve the financial health and management of the Town; and

WHEREAS, the Town of Southwest Ranches currently does not have a fund balance policy to govern non-spendable, restricted, committed, assigned, and unassigned fund balances; and

WHEREAS, the Town Council has determined that it is necessary to establish guidelines for preserving adequate general fund's unassigned fund balance; and

WHEREAS, the fund balance policy sets standards for the use and replenishment of unassigned fund balance when it is drawn down below the recommended target level; and

WHEREAS, the Town Council deems that is in the best interest of the residents to enact a fund balance policy as set forth below; and

NOW, THEREFORE BE IT RESOLVED by the Town Council of the Town of Southwest Ranches, Florida as follows:

Section 1: Recitals. The above-referenced recitals are true and correct and are incorporated herein by reference.

Section 2: Adoption. The Town Council hereby approves the adoption of the Town of Southwest Ranches fund balance policy attached hereto as "Exhibit A" and authorizes the Town Administrator and Town Financial Administrator to implement these changes as needed.

Section 3: Severability. If any one or more provisions of this Resolution shall be held contrary to any express provision of law or contrary to the policy of express law, though not expressly prohibited or against public policy, or shall for any reason whatsoever be held invalid, then such provision shall be null and void and shall be separate from the remaining provisions, and shall in no way affect the validity of all other provisions of this Resolution.

Section 4: Effective Date. This Resolution shall take effect immediately upon its adoption.

PASSED AND ADOPTED by the Town Council of the Town of Southwest Ranches, Florida, this 23 day of January 2025, on a motion by

_____ and seconded by _____

Breitkreuz _____
Hartmann _____
Allbritton _____
Jablonski _____
Kuczenski _____

Ayes _____
Nays _____
Absent _____

Steve Breitkreuz, Mayor

ATTEST:

Debra Ruesga, Town Clerk

Approved as to Form and Correctness:

Keith M. Poliakoff, J.D., Town Attorney
1001.003.2025



INVESTMENT POLICY FOR

THE

TOWN OF SOUTHWEST RANCHES

Adopted on January XX, 20XX

TABLE OF CONTENTS

<u>SECTION</u>	<u>PAGE</u>
I. PURPOSE	3
II. SCOPE	3
III. INVESTMENTS OBJECTIVES	3
IV. DELEGATION OF AUTHORITY	4
V. STANDARDS OF PRUDENCE	4
VI. ETHICS & CONFLICTS OF INTEREST	4
VII. INTERNAL CONTROLS & INVESTMENT PROCEDURES	5
VIII. CONTINUING EDUCATION	5
IX. AUTHORIZED INVESTMENT INSTITUTIONS & DEALERS	5
X. MATURITY & LIQUIDITY REQUIREMENTS	6
XI. RISK & DIVERSIFICATION	6
XII. MASTER REPURCHASE AGREEMENT	6
XIII. COMPETITIVE SELECTION OF INVESTMENT INSTRUMENTS	6
XIV. AUTHORIZED INVESTMENT INSTRUMENTS & PORTFOLIO COMPOSITION	7
XV. DERIVATIVES & REVERSE REPURCHASE AGREEMENTS	10
XVI. PERFORMANCE MEASUREMENTS	10
XVII. REPORTING	11
XVIII. THIRD-PARTY CUSTODIAL AGREEMENTS	11
XIX. INVESTMENT POLICY REVIEW & ADOPTION	12

I. PURPOSE

The purpose of this Investment Policy (hereinafter “Policy”) is to set forth the investment objectives and parameters for the management of public funds of the Town of Southwest Ranches (hereinafter “Town”). This Policy is designed to safeguard the Town’s funds, the availability of operating and capital funds when needed, and an investment return competitive with comparable funds and financial market indices.

II. SCOPE

In accordance with Section 218.415, Florida Statutes, this Policy applies to all cash and investments held or controlled by the Town and shall be identified as “general operating funds” of the Town with the exception of funds needed to meet current expenses, funds related to the issuance of debt where there are other existing policies or indentures in effect for such funds, and any future revenues, which have statutory investment requirements conflicting with this Policy and funds held by state agencies (e.g., Department of Revenue). Additionally, this Policy does not apply to pension funds such as, the employees’ pension/retirement funds. Escrow funds held to pay and defease refunded bonds shall be invested in accordance with the terms of the escrow deposit agreement. Cash and investment balances as defined in this section are entirely known as “available fund”.

III. INVESTMENT OBJECTIVES

Safety of Principal

The foremost objective of this investment policy is the safety of the principal of those funds within the portfolios. Investment transactions shall seek to keep capital losses at a minimum, whether they are from securities defaults or erosion of market value. To attain this objective, diversification is required in order that potential losses on individual securities do not exceed the income generated from the remainder of the portfolio.

Maintenance of Liquidity

The portfolios shall be managed in such a manner that funds are available to meet reasonably anticipated cash flow requirements in an orderly manner. Periodic cash flow analyses will be completed to ensure that the portfolios are positioned to provide sufficient liquidity.

Return on Investment

Investment portfolios shall be designed with the objective of attaining a market rate of return throughout budgetary and economic cycles, considering the investment risk constraints and liquidity needs. Return on investment is of least importance compared to the safety and liquidity objectives described above.

Return is attempted through active management where the Town Financial Administrator, designee, and investment advisor (hereinafter “investment team”) utilizes a total return strategy (which includes both realized and unrealized gains and losses in the portfolio). This total return strategy seeks to increase the value of the portfolio through reinvestment of income and capital gains. The core of investments is limited to relatively low risk securities in anticipation of earning a fair return relative to the risk being assumed. Despite this, the “investment team” may trade to recognize a loss from time to time to achieve a perceived relative value based

on its potential to enhance the total return of the portfolio.

IV. DELEGATION OF AUTHORITY

In accordance with the Town's charter (Section 3.11), the responsibility for providing oversight in regard to the management of the investment program resides with the Town Financial Administrator. The Town Financial Administrator or designee will be responsible for transferring the appropriate funds to effect investment transactions, in accordance with the investment policy and/or as recommended by the Town's investment advisor if one is contractually engaged, for the investment program. No person may engage in an investment transaction except as stated in the internal controls section of the policy. In employing an investment advisor or firm to manage the Town's investment portfolio or a portion of its available fund, the investment advisor or firm must be registered under the Investment Adviser's Act of 1940.

V. STANDARDS OF PRUDENCE

The standard of prudence to be used by the investment team shall be the "Prudent Person" standard and shall be applied in the context of managing the overall investment program. The Town Financial Administrator or designee (hereinafter "investment officers") acting in accordance with written procedures and this Policy and exercising due diligence shall be relieved of personal responsibility for an individual security's credit risk or market price changes, provided deviations from expectation are reported to the Town Council in a timely fashion and the liquidity and the sale of securities are carried out in accordance with the terms of this Policy. The "Prudent Person" rule states the following:

Investments shall be made with judgment and care, under circumstances then prevailing, which persons of prudence, discretion and intelligence exercise in the management of their own affairs, not for speculation, but for investment, considering the probable safety of their capital as well as the probable income to be derived from the investment. 218.415(4) F.S.

While the standard of prudence to be used by investment officers is the Prudent Person standard, any person or firm hired or retained to invest, monitor, or advise concerning these assets shall be held to the higher standard of "Prudent Expert". The standard shall be that in investing and reinvesting moneys and in acquiring, retaining, managing, and disposing of investments of these funds, the contractor shall exercise: the judgment, care, skill, prudence, and diligence under the circumstances then prevailing, which persons of prudence, discretion, and intelligence, acting in a like capacity and familiar with such matters would use in the conduct of an enterprise of like character and with like aims by diversifying the investments of the funds, so as to minimize the risk, considering the probable income as well as the probable safety of their capital.

VI. ETHICS & CONFLICTS OF INTEREST

Investment officers involved in the investment process shall refrain from personal business activity that could conflict with proper execution of the investment program, or which could impair their ability to make impartial investment decisions. Also, the above personnel involved in the investment process shall disclose to the Town Council any material financial interests in financial institutions that conduct business with the Town, and they shall further disclose any material personal financial/investment positions that could be related to the performance of the Town's investment program. The investment team shall refrain from undertaking personal investment transactions with the same individual with whom business is conducted on behalf of their entity.

VII. INTERNAL CONTROLS & INVESTMENT PROCEDURES

The Town Financial Administrator shall establish a system of internal controls and operational procedures that are in writing and made a part of the Town's finances operational procedures. The internal controls should be designed to prevent losses of funds, which might arise from fraud, employee error, and misrepresentation by third parties, or imprudent actions by employees. The written procedures should include reference to safekeeping, repurchase agreements, separation of transaction authority from accounting and recordkeeping, wire transfer agreements, banking service contracts, collateral/depository agreements, and "delivery-vs-payment" procedures. No person may engage in an investment transaction except as authorized under the terms of this Policy.

Independent auditors, as a normal part of the annual financial audit to the Town, shall conduct a review of the system of internal controls to ensure compliance with policies and procedures.

VIII. CONTINUING EDUCATION

The Town Financial Administrator and any other personnel responsible for overseeing investments or designee shall annually complete 8 hours of continuing education in subjects or course of study related to investment practices and products pursuant to section 218.415(14) F.S.

IX. AUTHORIZED INVESTMENT INSTITUTIONS & DEALERS

The investment team shall only purchase securities from the following financial and investment institutions:

- A. Certificates of deposit, money market accounts, and savings accounts.
These investments may only be purchased from public depositories qualified by the Treasurer of the State of Florida, in accordance with Chapter 280, Florida Statutes.
- B. Overnight Repurchase Agreement.
Collateral for the Town's "Sweep Accounts" shall be held at Town's depository bank which must be a State Qualified Public Depository (QPD).
- C. Qualified Institutions for all other Investments.
 1. Primary dealers as defined by the Federal Reserve Bank of New York; or
 2. Large regional and money market center banks ranked 1-10 in total capital nationally as rated by the Federal Deposit Insurance Corporation, and Qualified Public Depositories, as defined in Section 280.02, Florida Statutes; or
 3. Smaller regional broker-dealers based in the State of Florida meeting the following criteria:
 - a) Must comply with the SEC mandated Minimum Net Capital Rule 15c3-1;
 - b) Must provide their most recent Financial and Operational Combined Uniform Single (FOCUS) report showing a minimum net capital of \$10 million on either line 3750 or line 3760 of the Report;
 - c) Must have been in continuous business operations for the five (5) years preceding the date of application to be a broker-dealer that is a qualified institution; and
 - d) If it is a banking institution, it must be a Qualified Public Depository, as defined in Section 280.02, Florida Statutes.

Qualified Institutions must have the ability to confirm trades through an electronic trading platform and must complete a broker agreement prior to initial trade. An annual review of - dealers will be conducted at the end of each fiscal year. A list containing a maximum of fifteen (15) approved broker-dealers selected on creditworthiness will be maintained annually.

The Town's contracted investment advisor shall utilize and maintain its own list of approved primary and non- primary dealers.

X. MATURITY & LIQUITY REQUIREMENTS

To the extent possible, investment maturities will be matched with known cash needs and anticipated cash flow requirements.

A. Maturity Guidelines:

Securities purchased by or on behalf of the Town shall have a final maturity of five and a half years (5.5) or less from the date of settlement. The maximum effective duration of the entire portfolio shall be three (3) years. The maturities of the underlying securities of a repurchase agreement will follow the requirements of the Securities Industry and Financial Markets Association (SIFMA) Master Repurchase Agreement.

B. Liquidity Requirements:

The Town Financial Administrator or designee shall determine the approximate amount of funds required to meet the day-to-day expenditure needs of the Town. All funds in the depository bank(s) will be "swept" into a money market fund as necessary to maintain liquidity flexibility. The balance of the Town's funds will be available for investment according to the guidelines incorporated within this Policy.

XI. RISK & DIVERSIFICATION

Assets held shall be diversified to control risks resulting from overconcentration of assets in a specific maturity, issuer, instruments, dealer, or bank through which these instruments are bought and sold. The Town Financial Administrator shall determine diversification strategies within the established guidelines.

XII. MASTER REPURCHASE AGREEMENT

The Town Financial Administrator will require all approved institutions and dealers transacting repurchase agreements to execute and perform as stated in the Securities Industry and Financial Markets Association (SIFMA) Master Repurchase Agreement. All repurchase agreement transactions will adhere to requirements of the SIFMA Master Repurchase Agreement.

XIII. COMPETITIVE SELECTION OF INVESTMENT INSTRUMENTS

After the "investment team" have determined the approximate maturity date based on cash flow needs and market conditions and have analyzed and selected one or more optimal types of investments, a minimum of three (3) qualified banks and/or approved broker/dealers must be contacted and asked to provide bids/offers on securities in question. Bids will be held in confidence until the bid deemed to best meet the investment objectives is determined and selected.

However, if obtaining bids/offers are not feasible and appropriate, securities may be purchased/sold utilizing the comparison to current market price method on an exception basis. Acceptable current market price providers include, but are not limited to:

- A. Tradeweb
- B. Bloomberg Information Systems
- C. Wall Street Journal or a comparable nationally recognized financial publication providing daily market pricing
- D. Daily market pricing provided by the Town's custodian or their correspondent institutions

The "investment team" shall utilize the competitive bid process to select the securities to be purchased or sold. Selection by comparison to the current market price, as indicated above, shall only be utilized when, in judgment of the Town Financial Administrator or designee and the Town's investment advisor(s), competitive bidding would inhibit the selection process.

Examples of when this method may be used include:

- A. When time constraints due to unusual circumstances preclude the use of the competitive bidding process.
- B. When no active market exists for the issue being traded due to the age or depth of the issue.
- C. When a security is unique to a single dealer, for example, a private placement.
- D. When the transaction involves new issues or issues in the "when issued" market.

Overnight sweep investment instruments will not be bid but may be placed with the Town's depository bank relating to the demand account for which the investment instrument was purchased.

XIV. AUTHORIZED INVESTMENTS, INSTRUMENTS & PORTFOLIO COMPOSITION

Investments should be made subject to the cash flow needs and such cash flows are subject to revisions as market conditions and the Town's needs change. The Town's Financial Services Department is responsible for updating cash flow projections and expenditure projections over \$100,000 on a monthly basis. However, when the invested funds are needed in whole or in part for the purpose originally intended or for more optimal investments, the Town Financial Administrator may authorize the sale of the investment at the then-prevailing market price and place the proceeds into the proper account at the Town's custodian.

The following are the investment requirements and allocation limits on security types, issuers, and maturities as established by the Town. Diversification strategies within the established guidelines shall be reviewed and revised periodically as necessary by the Town Financial Administrator. The Town Financial Administrator shall have the option to further restrict investment percentages from time to time based on market conditions, risk and diversification investment strategies. The percentage allocations requirements for investment types and issuers are calculated based on the original cost of each investment, at the time of purchase. Investments not listed in this Policy are prohibited. The following requirements do not apply to funds derived from the sale of debt.

Permitted Investments

Sector	Sector Maximum (%)	Per Issuer Maximum (%)	Minimum Ratings Requirement ¹	Maximum Maturity
U.S. Treasury	100%	100%	N/A	3.50 Years
GNMA		40%		
Other U.S. Government Guaranteed (e.g. AID, GTC)		10%		
Federal Agency/GSE: FNMA, FHLMC, FHLB, FFCB*	100%	40% ³	N/A	3.50 Years
Corporates	50% ²	5%	Highest ST or Three Highest LT Rating Categories (A-1/P-1, A-/A3 or equivalent)	3.50 Years
Municipals	25%	10%	Highest ST or Three Highest LT Rating Categories (SP-1/MIG 1, A-/A3, or equivalent)	3.50 Years
Agency Mortgage-Backed Securities (MBS)	30%	40% ³	N/A	3.50 Years Avg. Life ⁴
Asset-Backed Securities (ABS)	25%	10%	Highest ST or LT Rating (A-1+/P-1, AAA/Aaa, or equivalent)	3.50 Years Avg. Life ⁴
Non-Negotiable Collateralized Bank Deposits (CD) or Savings Accounts	50%	25% or None, if fully collateralized	Secured by the Florida Security for Public Deposits Act, Chapter 280, Florida Statutes. None, if fully collateralized.	1 Year
Commercial Paper (CP)	35% ²	10%	Highest ST Rating Category (A-1/P-1, or equivalent)	270 Days
Repurchase Agreements (Repo or RP)	20%	20%	Counterparty (or if the counterparty is not rated by an NRSRO, then the counterparty's parent) must be rated in the Highest ST Rating Category (A-1/P-1, or equivalent) If the counterparty is a Federal Reserve Bank, no rating is required	1 Year
Money Market Funds (MMFs)	50%	25%	Two Highest Fund Rating by all NRSROs who rate the fund (AAm/Aa-mf, or equivalent)	N/A
Intergovernmental Pools (LGIPs)	50% ⁵	50%	Highest Fund Quality and Volatility Rating Categories by all NRSROs who rate the LGIP, (AAAm/AAAf, S1, or equivalent)	N/A
Florida Local Government Surplus Funds Trust Funds ("Florida Prime" or "SBA")	75% ⁵	N/A	Highest Fund Rating by all NRSROs who rate the fund (AAAm/Aaa-mf, or equivalent)	N/A

Notes:

¹ Rating by at least one SEC-registered Nationally Recognized Statistical Rating Organization ("NRSRO"), unless otherwise noted. ST=Short-term; LT=Long-term.

² Maximum allocation to all corporate and bank credit instruments is 50% combined.

³ Maximum exposure to any Federal Agency, including the combined holdings of Agency debt and Agency MBS, is 40%.

⁴ The maturity limit for MBS and ABS is based on the expected average life at time of settlement, measured using Bloomberg or other industry standard methods.

⁵ The maximum exposure to Florida Prime and Intergovernmental Pools is a combined 75%.

* Federal National Mortgage Association (FNMA); Federal Home Loan Mortgage Corporation (FHLMC); Federal Home Loan Bank or its District Banks (FHLB); Federal Farm Credit Bank (FFCB).

- 1) **U.S. Treasury & Government Guaranteed** – U.S. Treasury obligations, and obligations the principal and interest of which are backed or guaranteed by the full faith and credit of the U.S. Government.
- 2) **Government National Mortgage Association (GNMA) Securities** – Also known as Ginnie Mae, these bonds are backed by the full faith and credit of the United States government.
- 3) **Federal Agency/GSE (government-sponsored enterprise)** – Debt obligations, participations or other instruments issued or fully guaranteed by any U.S. Federal agency, instrumentality or GSE.
- 4) **Corporates** – U.S. dollar denominated corporate notes, bonds or other debt obligations issued or guaranteed by a domestic or foreign corporation, financial institution, non-profit, or other entity.
- 5) **Municipals** – Obligations, including both taxable and tax-exempt, issued or guaranteed by any State, territory or possession of the United States, political subdivision, public corporation, authority, agency board, instrumentality or other unit of local government of any State or territory.
- 6) **Agency Mortgage-Backed Securities** – Mortgage-backed securities (MBS), backed by residential, multi-family or commercial mortgages, that are issued or fully guaranteed as to principal and interest by a U.S. Federal agency or government sponsored enterprise, including but not limited to pass-throughs.
- 7) **Asset-Backed Securities** – Asset-backed securities (ABS) whose underlying collateral consists of loans, leases or receivables, including but not limited to auto loans/leases, credit card receivables, or equipment loans/leases.
- 8) **Non-Negotiable Certificate of Deposit and Savings Accounts** – Non-negotiable interest-bearing time certificates of deposit, or savings accounts in banks organized under the laws of this state or in national banks organized under the laws of the United States and doing business in this state, provided that any such deposits are secured by the Florida Security for Public Deposits Act, Chapter 280, Florida Statutes.
- 9) **Commercial Paper** – U.S. dollar denominated commercial paper issued or guaranteed by a domestic or foreign corporation, company, financial institution, trust or other entity, including both unsecured debt and asset-backed programs.
- 10) **Repurchase Agreements** – Repurchase agreements (Repo or RP) that meet the following requirements:
 - a. Must be governed by a written SIFMA Master Repurchase Agreement which specifies securities eligible for purchase and resale, and which provides the unconditional right to liquidate the underlying securities should the Counterparty default or fail to provide full timely repayment.
 - b. Counterparty must be a Federal Reserve Bank, a Primary Dealer as designated by the Federal Reserve Bank of New York, or a Federal Reserve Bank.
 - c. Securities underlying repurchase agreements must be delivered to a third-party custodian under a written custodial agreement and may be of deliverable or tri-party form. Securities must be held in the City's custodial account or in a separate account in the name of the City.
 - d. Acceptable underlying securities include only securities that are direct obligations of, or that are fully guaranteed by, the United States or any agency of the United States, or U.S. Agency-backed mortgage related securities.

- e. Underlying securities must have an aggregate current market value of at least 102% (or 100% if the counterparty is a Federal Reserve Bank) of the purchase price plus current accrued price differential at the close of each business day.
- f. Final term of the agreement must be 1 year or less.

11) **Money Market Funds** – Shares in open-end and no-load money market mutual funds, provided such funds are registered under the Investment Company Act of 1940 and operate in accordance with Rule 2a- 7.

A thorough investigation of any money market fund is required prior to investing, and on an annual basis. Attachment A is a questionnaire that contains a list of questions to be answered prior to investing, that covers the major aspects of any investment pool/fund. A current prospectus must be obtained.

12) **Local Government Investment Pools** – State, local government or privately-sponsored investment pools that are authorized pursuant to state law.

A thorough investigation of any intergovernmental investment pool is required prior to investing, and on an annual basis. Attachment A is a questionnaire that contains a list of questions to be answered prior to investing, that covers the major aspects of any investment pool/fund. A current prospectus must be obtained.

13) **The Florida Local Government Surplus Funds Trust Funds (“Florida Prime” or “SBA - State Board of Administration”)** – A thorough investigation of the Florida Prime is required prior to investing, and on an annual basis. Attachment A is a questionnaire that contains a list of questions to be answered prior to investing, that covers the major aspects of any investment pool/fund. A current prospectus or portfolio report must be obtained.

XV. DERIVATIVES & REVERSE REPURCHASE AGREEMENTS

The Town may not invest in investment products that include the use of derivatives or in reverse repurchase agreements. A “derivative” is defined as a financial instrument the value of which depends on, or is derived from, the value of one or more underlying assets or indices or asset values. Agency mortgage-backed securities, including collateralized mortgage obligations, known as “CMO”, will not be considered a derivative product for purposes of investment provided that the investment meets all other criteria of this policy statement including the policy objectives of safety and liquidity.

XVI. PERFORMANCE MEASUREMENTS

In order to assist in the evaluation of the portfolios’ performance, the Town will use performance benchmarks for short-term and long-term portfolios. The use of benchmarks will allow the Town to measure its returns against other investors in the same markets.

- A. Investment performance of funds designated as short-term funds and other funds that must maintain a high degree of liquidity will be compared to the return on the S&P Rated GIP Index Government 30 Day Yield.
- B. The long-term investment portfolio shall be designed with the annual objective of meeting the return of the ICE BofA 1-3 Year U.S. Corporate & Government Index compared to the portfolio’s total rate of return. This index and maturity range approximates the permitted investment by this policy and will be utilized as a benchmark to be compared to the portfolio’s total rate of return.

XVII. REPORTING

- A. The Town Financial Administrator will prepare as deemed necessary investment reports which include the listing of holdings in the portfolio at cost and market value for the Town Administrator. At least annually, the Town Financial Administrator, designee, or investment advisor shall prepare and submit an investment report to the Town Council. Schedules for the annual report should include but not limited to:
1. A listing of individual securities held at the end of the reporting period
 2. Percentage of available funds represented by each investment type
 3. Coupon, discount or earning rate
 4. Average life or duration and final maturity of all investments
 5. Par value, and market value
 6. Income earned

XVIII. THIRD-PARTY CUSTODIAL AGREEMENTS

Securities, with the exception of certificates of deposits, shall be held with a third-party custodian, and all securities purchased by, and all collateral obtained by the Town should be designated in the books and records of the custodian as an asset of the Town. The securities must be held in an account separate and apart from the assets of the financial institution. A third party custodian is defined as any bank depository chartered by the Federal Government, the State of Florida, or any other state or territory of the United States which has a branch or principal place of business in the State of Florida as defined in Section 658.12, Florida Statutes, or by a national association organized and existing under the laws of the United States which is authorized to accept and execute trusts and which is doing business in the State of Florida. Certificates of deposits will be placed in the custodian's safekeeping department for the term of the deposit.

The custodian shall accept transaction instructions only from those persons who have been duly authorized by the Town Financial Administrator and which authorization has been provided, in writing, to the custodian. No withdrawal of securities, in whole or in part, shall be made from safekeeping, shall be permitted unless authorized in writing by such a duly authorized person.

The custodian shall provide the Town Financial Administrator or designee with safekeeping receipts that provide detailed information on the securities held by the custodian. Security transactions between a broker/dealer and the custodian involving the purchase or sale of securities by transfer of money or securities must be made on a "delivery vs. payment" basis, if applicable, to ensure that the custodian will have the security or money, as appropriate, in hand at the conclusion of the transaction. Securities held as collateral shall be held free and clear of any liens.

XIX. INVESTMENT POLICY REVIEW AND ADOPTION

The investment policy shall be adopted by resolution. The Town Financial Administrator will review the policy annually for modifications and make recommendations to the Town Council. The Town Council shall approve any necessary modifications.

Attachment A
Investment Pool/Fund Questionnaire

General Fund/Pool Information:

1. Does the fund/pool attempt to maintain a stable net asset value or floating net asset value?
2. How is interest distributed, and how are gains and losses treated?
3. How often are statements and portfolio holdings distributed?
4. Is the fund/pool eligible for bond proceeds and/or will it accept such proceeds?

Oversight:

1. What is the fund/pool ratings by the Nationally Recognized Statistical Rating Organizations such as S&P, Moody's, Fitch, Kroll, etc.?
2. What are the eligible investment securities? Is there a written statement of investment policy and objectives?
3. How are the securities safeguarded (including the settlement processes)? How often are the securities priced? How often is the fund/pool audited?
4. Is there any additional oversight outside of the Board of Trustees?

Fund/Pool Statistics:

1. What is the current sector allocation of the fund/pool?
2. What is the fee schedule, and how and when is it assessed?

Liquidity:

1. Does the fund/pool follow GASB 79? (Statement 79 - Certain External Investment Pools & Pool Participants, June 15, 2015).
2. Does the fund/pool have any liquidity fees? If so, describe the terms.
3. Does the fund/pool have redemption gates? If so, describe them.

Investor Requirements:

1. Who may invest in the program, how often, and what size deposits and withdrawals are allowed?
2. Is there a limit regarding investor concentration? If so, what is it?



This page
intentionally left blank



Town of Southwest Ranches
13400 Griffin Road
Southwest Ranches, FL 33330-
2628

(954) 434-0008 Town Hall
(954) 434-1490 Fax

Town Council
Steve Breitkreuz, Mayor
Bob Hartmann, Vice Mayor
Jim Allbritton, Council Member
Gary Jablonski, Council Member
David S. Kuczenski, Esq., Council Member

Russell C. Muniz, MBA, MPA, Town Administrator
Keith M. Poliakoff, JD, Town Attorney
Debra M. Ruesga, Town Clerk
Emil C. Lopez, CPM, Town Financial Administrator

COUNCIL MEMORANDUM

TO: Honorable Mayor Breitkreuz and Town Council
VIA: Russell Muñiz, Town Administrator
FROM: Thomas Holste, General Services Manager
DATE: 1/23/2025
SUBJECT: Second Phase of Purchase and Replacement of 15 Laptops

Recommendation

Town Council consideration for a motion to approve the resolution.

Unanimous Vote of the Town Council Required?

No

Strategic Priorities

- A. Sound Governance
- B. Enhanced Resource Management
- D. Improved Infrastructure

Background

The Town's laptops which are a critical component of our information technology infrastructure are in their 6th year of use and at the end of their useful life. Per our contractual agreement with the City of Tamarac the Town is required to use similar equipment to Tamarac's in the Town's office environment.

The adopted Fiscal Year 2025 Budget provides for the completion of a two-year computer replacement schedule that allows for the remaining replacement of 15 laptops in FY 2025. Lenovo (United States), Inc. submitted a quote based on Omnia Partners Contract (NCPA-01-146) for new laptops in the amount of \$31,512.00.

The Town believes it is in the Town's best interest to purchase 15 new Lenovo laptops in the amount of Thirty-One Thousand Five Hundred Twelve Dollars and Zero Cents (\$31,512.00) as outlined in the Quotation (Exhibit A) received from Lenovo (United States), Inc.

Fiscal Impact/Analysis

The adopted Fiscal Year 2025 Budget provides for the second year of a two-year computer replacement schedule (Program Modification) that allows for the replacement of 15 laptops in FY 2025 (001-3900-519-64100).

Staff Contact:

Thomas Holste, General Services Manager
Russell Muñiz, Town Administrator

ATTACHMENTS:

Description	Upload Date	Type
Resolution - TA Approved	1/16/2025	Resolution
Exhibit A	1/15/2025	Exhibit

RESOLUTION NO. 2025 - XXX

A RESOLUTION OF THE TOWN COUNCIL OF THE TOWN OF SOUTHWEST RANCHES, FLORIDA, APPROVING A PIGGYBACK OF OMNIA PARTNERS CONTRACT (OMNIA PARTNERS (NCPA)-01-146) FOR THE ISSUANCE OF A PURCHASE ORDER IN AN AMOUNT NOT TO EXCEED THIRTY ONE THOUSAND FIVE HUNDRED TWELVE DOLLARS AND ZERO CENTS (\$31,512.00) TO LENOVO (UNITED STATES) INC. FOR LENOVO LAPTOPS; AUTHORIZING THE MAYOR, TOWN ADMINISTRATOR AND TOWN ATTORNEY TO EXECUTE ALL DOCUMENTS NECESSARY TO EFFECTUATE THE INTENT OF THIS RESOLUTION; AND PROVIDING AN EFFECTIVE DATE.

WHEREAS, the Town's laptops which are a critical component of our information technology infrastructure are in their 6th year of use and at the end of their useful life; and

WHEREAS, per our contractual agreement with the City of Tamarac the Town is required to use similar equipment to Tamarac's in the Town's office environment; and

WHEREAS, the adopted Fiscal Year 2025 Budget provides for the completion of a two-year computer replacement schedule that allows for the remaining replacement of 15 laptops in FY 2025; and

WHEREAS, Lenovo (United States), Inc. submitted a quote based on Omnia Partners Contract (NCPA-01-146) for new laptops in the amount of \$31,512.00; and

WHEREAS, the Town believes it is in the Town's best interest to purchase 15 new Lenovo laptops in the amount of Thirty-One Thousand Five Hundred Twelve Dollars and Zero Cents (\$31,512.00) as outlined in the Quotation (Exhibit A) received from Lenovo (United States), Inc.

NOW, THEREFORE, BE IT RESOLVED BY THE TOWN COUNCIL OF THE TOWN OF SOUTHWEST RANCHES, FLORIDA:

Section 1. The above-referenced recitals are true and correct and are incorporated herein by reference.

Section 2. The Town Council hereby approves the issuance of a Purchase Order in the amount of Thirty-One Thousand Five Hundred Twelve Dollars and Zero Cents (\$31,512.00) to Lenovo (United States), Inc. for new Lenovo Laptops as outlined in the attached Quotation (see Exhibit "A").

Section 3. This Resolution shall take effect upon its passage and adoption.

PASSED AND ADOPTED by the Town Council of the Town of Southwest

Ranches, Florida, this 23rd day of January, 2025, on a motion

by _____ and seconded by _____.

Breitkreuz _____
Hartmann _____
Allbritton _____
Jablonski _____
Kuczenski _____

Ayes _____
Nays _____
Absent _____

Steve Breitkreuz, Mayor

ATTEST:

Debra Ruesga, CMC, Town Clerk

Approved as to Form and Correctness:

Keith Poliakoff, J.D., Town Attorney
1001.005.2025

Customer Name: TOWN OF
SOUTHWEST
RANCHES

Lenovo (United States) Inc.

Customer Number: 1215061534



Bid Request No. BRPNS007200467 V1

Sales Representative: Alexander Moore

Created On: 18-Dec-2024

Phone Number:

Last Updated: 18-Dec-2024

Email: amoore6@lenovo.com

Lenovo Master Contract No. MC98302921

Lenovo Pricing Contract: 5325946875

Customer Contract No. CUSNP221-Omnia
Partners (NCPA)-01-
146

Lenovo Contract Code: CUSNP221

Thank you for requesting a quote from Lenovo. Your complete quote information is included below. Please feel free to reach me by phone or email if you need further assistance.

PRODUCT AND SERVICE DETAILS

Part Number	Description	F/B	Qty	List Price	Unit Price	End Date	Total
21HRS6P100	ThinkPad X1 Yoga G8, Intel® Core™ i7- 1365U vPro® (E-cores up to 3.90GHz, 12MB) 14 1920 x 1200 Touch, Windows 11 Pro 64, 32.0GB, 1x1TB SSD M.2 2280 PCIe Gen4 Performance TLC Opal, Intel® Iris® Xe Graphics, NFC,BT5.1 or BT5.3,Intel®AX211vPr L860-GL, No Wired Ethernet, FHD IR , 4 Cell Li-Pol 57Wh, 3YR Premier Support Plus,Backlit, Grey- English (US)	F	14	5,555.00	2,048.00	05-Dec-2025	28,672.00
21FBSFUE00	ThinkPad P16 G2, Intel® Core™ i9- 13950HX vPro® (E- cores up to 4.00GHz, 36MB) 16 3840 x 2400 Touch, Windows 11 Pro 64, 64.0GB, 1x1TB SSD M.2 2280 PCIe Gen4 Performance TLC Opal, NVIDIA RTX™ 1000 Ada 6GB, BT5.1 or BT5.3,Intel®AX211vPro, No Wired Ethernet, 1080P FHD, 6 Cell Li- Pol 94Wh, 3YR Premier NBD,Backlit, Grey with Number Pad-English (US)	F	1	8,635.00	2,840.00	05-Dec-2025	2,840.00

Part Number	Description	F/B	Qty	List Price	Unit Price	End Date	Total
						Grand Total	USD 31,512.00

CONFIGURATION DETAILS

Part Number	SKU (MTM_VK)	Component	Description	Qty
21HRS6P100			ThinkPad X1 Yoga G8, Intel® Core™ i7-1365U vPro® (E-cores up to 3.90GHz, 12MB) 14 1920 x 1200 Touch, Windows 11 Pro 64, 32.0GB, 1x1TB SSD M.2 2280 PCIe Gen4 Performance TLC Opal, Intel® Iris® Xe Graphics, NFC,BT5.1 or BT5.3,Intel®AX211vPro,Fibocom L860-GL, No Wired Ethernet, FHD IR , 4 Cell Li-Pol 57Wh, 3YR Premier Support Plus,Backlit, Grey-English (US)	14
	5WS1L39079	SERVICE	WARRANTY 3Y Premier Support Plus	1
	21HR_VK00104244	Athena Certified Model	Evo Certified	1
	21HR_VK00061132	Fingerprint Reader	Fingerprint Reader	1
	21HR_VK00152051	Endpoint Management	No Endpoint Management	1
	21HR_SBB1B66833	ICPS	ICPS Enabled	1
	21HR_SBB1F51852	Display Shell	14" WUXGA (1920 x 1200), IPS, Anti-Reflective, Touch, 100%sRGB, 400 nits, Narrow Bezel, FHD IR/RGB Hybrid with with Dual Array Microphone and ThinkShutter	1
	21HR_VK00071385	Color	Grey	1
	21HR_VK00107557	Graphics	Integrated Intel® Iris® Xe Graphics	1
	21HR_VK00061438	GEO	NA	1
	21HR_VK00122692	Ethernet	No Wired Ethernet	1
	21HR_VK00112009	OS DPK	W11 Pro	1
	21HR_VK00087784	Premier Asset Tag	Premier Support Asset Tag	1
	21HR_VK00028571	Preload Type	Standard Image (Preload)	1
	21HR_VK00111980	Cloud Security Software	No Cloud Security Software	1
	21HR_SBB0V88740	Publication	Publication - Polish/Portuguese/English	1
	21HR_VK00071091	Warranty	3 Year On-site	1
	21HR_SBB0Z70644	Storage Selection	1 TB SSD M.2 2280 PCIe Gen4 Performance TLC Opal	1
	21HR_SBB1B67180	Power Adapter	65W USB-C Low Cost 90% PCC 2pin AC Adapter - US	1
	21HR_SBB0U37680	Integrated Wireless Antenna	WWAN Antenna	1
	21HR_VK00111040	Preload Language	Windows 11 Pro 64 English	1
	21HR_SBB0X80861	Publication 2	PUB POL/POR/BUL/BRL/SPA/ENG	1
	21HR_VK00085807	Graphic Dongle	No Graphics Dongle	1
	21HR_SBB0U37690	Keyboard	Backlit, Grey with Fingerprint Reader, NFC and WWAN - English	1
	21HR_VK00061519	WWAN Selection	WWAN	1
	21HR_SBB1J32894	Package Box Type	Single Standard Packaging	1
	21HR_VK00110011	Preload OS	Windows 11 Pro 64	1
	21HR_SBB1F51847	System Unit	X1Y8 i7-1365U VP IG+32G+211NE	1
	21HR_VK00122914	Display	14" WUXGA (1920 x 1200), IPS, Anti-Reflective,	1

EXHIBIT "A"

Part Number	SKU (MTM_VK)	Component	Description	Qty
			Touch, 100% sRGB, 400 nits, Narrow Bezel	
	21HR_VK00061379	Microsoft Label	Windows GML	1
	21HR_VK00153120	Wireless LAN	Intel® Wi-Fi 6E AX211 2x2 AX vPro® & Bluetooth® 5.1 (Windows 10) or Bluetooth® 5.3 (Windows 11)	1
	21HR_DY22202	NFC	NFC	1
	21HR_VK00154817	System Unit 2nd	D Cover WWAN GY	1
	21HR_VK00122905	Computer Vision	No Computer Vision	1
	21HR_VK00069954	Security Chip Setting	Enabled Discrete TPM2.0	1
	21HR_VK00153431	Processor	13th Generation Intel® Core™ i7-1365U vPro® Processor (E-cores up to 3.90 GHz P-cores up to 5.20 GHz)	1
	21HR_VK00122917	Onboard Memory	32 GB LPDDR5-6400MHz (Soldered)	1
	21HR_VK00085805	Electronic Privacy Filter	No ePrivacy Filter	1
	21HR_VK00106370	Battery	4 Cell Li-Polymer 57Wh	1
	21HR_VK00061089	Country/Region	USA	1
	21HR_VK00154556	vPro Certified Model	vPro Enterprise	1
	21HR_VK00122986	Camera	1080P FHD IR	1
	21HR_VK00085806	Ethernet Dongle	No Ethernet Dongle	1
	21HR_VK00080006	Absolute BIOS Selection	BIOS Absolute Enabled	1
	21HR_SBB0Z40351	Lenovo Pen	Lenovo Integrated Pen	1
	21HR_SBB1B94443	Wireless WAN	Fibocom L860-GL-16 4G LTE CAT16	1
	21HR_VK00153114	Microphone	4 Microphone	1
	21HR_SBB0S70762	CPU Label	Evo Core i7 vPro	1
	21HR_VK00120441	CO2 Offset Label	No CO2 Offset Label	1
	21HR_SBB0S70558	ASCII PW Support on BIOS	KBL_ID_ENG_KBLANG_409	1
	21HR_VK00110994	OS Type	Windows 11 Pro	1
	21HR_VK00105290	Transparent Supply Chain	No Transparent Supply Chain	1
	21HR_SBB1B67452	Region	ROW	1
	21HR_VK00085819	WWAN SIM Card	No WWAN SIM Card	1
	21HR_VK00153317	X1Y8 Others3	None	1
	21HR_VK00153316	X1Y8 Others2	None	1
	21HR_VK00153319	X1Y8 Others5	None	1
	21HR_VK00153318	X1Y8 Others4	None	1
	21HR_VK00153315	X1Y8 Others1	None	1
	21HR_VK00087795	Custom Asset Tag	None	1
	21HR_VK00084910	NBWARRANTY_CARD	None	1
	21HR_VK00061474	Cloud Recovery	None	1
	21HR_VK00144277	Second Security Software	None	1
	21HR_VK00061137	Microsoft Office	None	1
	21HR_VK00154988	Third Security Software	None	1
	21HR_VK00152052	Common2 2023	None	1
	21HR_VK00087802	Microsoft Autopilot	None	1
	21HR_VK00087798	Microsoft 4KHH	None	1

Part Number	SKU (MTM_VK)	Component	Description	Qty
		Report		
	21HR_VK00087799	ProvisionNow	None	1
	21HR_VK00087797	Digital Welcome	None	1
	21HR_VK00087800	Laser Etch and UV Print	None	1
	21HR_VK00087794	BIOS Customization	None	1
	21HR_VK00061481	Drop In Box	None	1
	21HR_VK00152054	Common4 2023	None	1
	21HR_VK00061664	Security Software	None	1
	21HR_VK00087796	Custom Image Type	None	1
	21HR_VK00152055	Common5 2023	None	1
	21HR_VK00061584	Adobe Elements	None	1
	21HR_VK00061583	Adobe Acrobat	None	1
	21HR_VK00106648	Adobe Creative Cloud	None	1
	21HR_VK00087804	vPro Factory Pre-provisioning	None	1
	21HR_VK00061495	Image Management	None	1
	21HR_VK00087801	Hard Drive Encryption	None	1
	21HR_VK00152053	Common3 2023	None	1
	21HR_VK00061644	Keyboard Patch	None	1
21FBSFUE00			ThinkPad P16 G2, Intel® Core™ i9-13950HX vPro® (E-cores up to 4.00GHz, 36MB) 16 3840 x 2400 Touch, Windows 11 Pro 64, 64.0GB, 1x1TB SSD M.2 2280 PCIe Gen4 Performance TLC Opal, NVIDIA RTX™ 1000 Ada 6GB, BT5.1 or BT5.3,Intel®AX211vPro, No Wired Ethernet, 1080P FHD, 6 Cell Li-Pol 94Wh, 3YR Premier NBD,Backlit, Grey with Number Pad-English (US)	1
	5WS0V07066	SERVICE	WARRANTY 3Y Premier Support	1
	21FB_VK00120679	Endpoint Management	No Endpoint Management	1
	21FB_VK00061132	Fingerprint Reader	Fingerprint Reader	1
	21FB_VK00152051	Endpoint Management	No Endpoint Management	1
	21FB_SBB1L34616	Display Shell	16" WQUXGA (3840 x 2400), OLED, Anti-Reflection/Anti-Smudge, Dolby Vision™, Touch, HDR 500 True Black, 100%DCI-P3, 400 nits, 60 Hz, Low Blue Light, 1080P FHD IR/RGB Hybrid with Mic, WLAN, WWAN, FCC	1
	21FB_SBB0S70306	Color Calibration	Factory Color Calibration	1
	21FB_VK00156998	DIMM Memory	64 GB DDR5-5600MHz (SODIMM) - (2 x 32 GB)	1
	21FB_VK00087784	Premier Asset Tag	Premier Support Asset Tag	1
	21FB_VK00028571	Preload Type	Standard Image (Preload)	1
	21FB_SBB0V88740	Publication	Publication - Polish/Portuguese/English	1
	21FB_VK00071091	Warranty	3 Year On-site	1
	21FB_SBB0Z70644	Storage Selection	1 TB SSD M.2 2280 PCIe Gen4 Performance TLC Opal	1
	21FB_VK00085807	Graphic Dongle	No Graphics Dongle	1
	21FB_SBB1B78209	Keyboard	Backlit, Grey with Number Pad - English (US)	1
	21FB_VK00110011	Preload OS	Windows 11 Pro 64	1

EXHIBIT "A"

Part Number	SKU (MTM_VK)	Component	Description	Qty
	21FB_SBB1L34599	System Unit	P16G2 i9-13950HX vPro+AX211 NE	1
	21FB_VK00157003	Display	16" WQUXGA (3840 x 2400), OLED, Anti-Reflection/Anti-Smudge, Dolby Vision™, Touch, HDR 500 True Black, 100%DCI-P3, 400 nits, 60 Hz, Low Blue Light	1
	21FB_SBB0P99850	Display Shell 2nd	Hinge Cap	1
	21FB_SBB1C55329	Offering Model	Relationship Model	1
	21FB_VK00061379	Microsoft Label	Windows GML	1
	21FB_SBB1G98666	Pointing Device	Trackpad, Fingerprint, No NFC, WWAN, Grey	1
	21FB_VK00122924	Wireless LAN	Intel® Wi-Fi 6E AX211 2x2 AX vPro® & Bluetooth® 5.1 (Windows 10) or Bluetooth® 5.3 (Windows 11)	1
	21FB_VK00061806	NFC	No NFC	1
	21FB_VK00157007	Lenovo Xiaotian	No Lenovo Xiaotian	1
	21FB_VK00157006	Transparent Supply Chain	No Transparent Supply Chain	1
	21FB_VK00157015	Processor	13th Generation Intel® Core™ i9-13950HX vPro® Processor (E-cores up to 4.00 GHz P-cores up to 5.50 GHz)	1
	21FB_SBB0H54071	Battery	6 Cell Li-Polymer 94Wh	1
	21FB_VK00061089	Country/Region	USA	1
	21FB_SBB0J09193	RAID Config	No	1
	21FB_VK00069855	Wireless WAN	No WWAN Card, with Antenna	1
	21FB_VK00120441	CO2 Offset Label	No CO2 Offset Label	1
	21FB_VK00061634	HDD Total Capacity	1 TB	1
	21FB_VK00110994	OS Type	Windows 11 Pro	1
	21FB_SBB1B67452	Region	ROW	1
	21FB_VK00085819	WWAN SIM Card	No WWAN SIM Card	1
	21FB_SBB0L63972	System Expansion Slots	No Smart Card Reader	1
	21FB_SBB1B66833	ICPS	ICPS Enabled	1
	21FB_SBB0N10538	Package Box	Standard	1
	21FB_SBB1L34802	Graphics	NVIDIA RTX™ 1000 Ada Generation Laptop GPU 6GB GDDR6	1
	21FB_VK00061438	GEO	NA	1
	21FB_VK00122692	Ethernet	No Wired Ethernet	1
	21FB_VK00109970	OS DPK	W11 Pro High End	1
	21FB_VK00111980	Cloud Security Software	No Cloud Security Software	1
	21FB_SBB0R37267	WLAN MISC PARTS	WLAN Misc Parts-WLAN Card	1
	21FB_SBB0S70346	Power Adapter	230W Slim 3pin AC Adapter - US	1
	21FB_VK00111040	Preload Language	Windows 11 Pro 64 English	1
	21FB_SBB0X80861	Publication 2	PUB POL/POR/BUL/BRL/SPA/ENG	1
	21FB_VK00061519	WWAN Selection	WWAN	1
	21FB_SBB1J32894	Package Box Type	Single Standard Packaging	1
	21FB_VK00086484	Graphic Dongle 2	No Graphics Dongle	1
	21FB_VK00062268	HDD Config	SSD	1
	21FB_VK00086618	Graphic Dongle 3	No Graphics Dongle	1
	21FB_SBB1L34600	System Unit 2nd	D Cover w/SIM Tray QN20 WX4	1
	21FB_VK00069954	Security Chip Setting	Enabled Discrete TPM2.0	1

EXHIBIT "A"

Part Number	SKU (MTM_VK)	Component	Description	Qty
	21FB_VK00154556	vPro Certified Model	vPro Enterprise	1
	21FB_VK00120678	Camera	1080P FHD IR Hybrid with Microphone	1
	21FB_VK00088628	RAID	No RAID	1
	21FB_VK00085806	Ethernet Dongle	No Ethernet Dongle	1
	21FB_VK00080006	Absolute BIOS Selection	BIOS Absolute Enabled	1
	21FB_VK00088978	Lenovo Pen	No Pen	1
	21FB_SBB1B66954	CPU Label	Core i9 vPro Enterprise	1
	21FB_SBB0S70558	ASCII PW Support on BIOS	KBL_ID_ENG_KBLANG_409	1
	21FB_VK00087795	Custom Asset Tag	None	1
	21FB_VK00084910	NBWARRANTY_CARD	None	1
	21FB_VK00061474	Cloud Recovery	None	1
	21FB_VK00061137	Microsoft Office	None	1
	21FB_VK00120680	Second Security Software	None	1
	21FB_VK00152052	Common2 2023	None	1
	21FB_VK00087798	Microsoft 4KHH Report	None	1
	21FB_VK00087799	ProvisionNow	None	1
	21FB_VK00087797	Digital Welcome	None	1
	21FB_VK00087800	Laser Etch and UV Print	None	1
	21FB_VK00061481	Drop In Box	None	1
	21FB_VK00157010	P16G2 Others5	None	1
	21FB_VK00157009	P16G2 Others4	None	1
	21FB_VK00120682	NONE	None	1
	21FB_VK00157008	P16G2 Others3	None	1
	21FB_VK00152054	Common4 2023	None	1
	21FB_VK00061664	Security Software	None	1
	21FB_VK00087796	Custom Image Type	None	1
	21FB_VK00106861	Second Storage Selection	None	1
	21FB_VK00152055	Common5 2023	None	1
	21FB_VK00120683	NONE	None	1
	21FB_VK00061584	Adobe Elements	None	1
	21FB_VK00061583	Adobe Acrobat	None	1
	21FB_VK00061495	Image Management	None	1
	21FB_VK00087801	Hard Drive Encryption	None	1
	21FB_VK00061644	Keyboard Patch	None	1
	21FB_VK00144277	Second Security Software	None	1
	21FB_VK00154988	Third Security Software	None	1
	21FB_VK00087802	Microsoft Autopilot	None	1
	21FB_VK00087794	BIOS Customization	None	1
	21FB_VK00106648	Adobe Creative Cloud	None	1
	21FB_VK00087804	vPro Factory Pre-provisioning	None	1
	21FB_VK00120681	NONE	None	1

Part Number	SKU (MTM_VK)	Component	Description	Qty
	21FB_VK00152053	Common3 2023	None	1

TERMS AND CONDITIONS

Prices quoted are valid through 16-Feb-2025 but are subject to change due to events outside Lenovo's reasonable control which may necessitate a price increase. Pricing does not include taxes, fees, or other charges which may be imposed on the items purchased.

Unless a separate agreement exists between Lenovo and Customer, all purchases are subject to the Lenovo Terms and Conditions displayed at the following internet address: <https://download.lenovo.com/lenovo/content/pdf/tnc/tc2.pdf>

Thank you for choosing Lenovo!

This page
intentionally left blank



Town of Southwest Ranches
13400 Griffin Road
Southwest Ranches, FL 33330-
2628

(954) 434-0008 Town Hall
(954) 434-1490 Fax

Town Council
Steve Breitreuz, Mayor
Bob Hartmann, Vice Mayor
Jim Allbritton, Council Member
Gary Jablonski, Council Member
David S. Kuczenski, Esq., Council Member

Russell C. Muniz, MBA, MPA, Town Administrator
Keith M. Poliakoff, JD, Town Attorney
Debra M. Ruesga, Town Clerk
Emil C. Lopez, CPM, Town Financial Administrator

COUNCIL MEMORANDUM

TO: Honorable Mayor Breitreuz and Town Council
VIA: Russell Muñiz, Town Administrator, ICMA-CM
FROM: Russell Muñiz, Town Administrator, ICMA-CM
DATE: 1/23/2025
SUBJECT: Reinstatement of the Public Safety and Traffic Committee

Recommendation

Town Council consideration to approve the resolution.

Unanimous Vote of the Town Council Required?

No

Strategic Priorities

- A. Sound Governance
- C. Reliable Public Safety
- E. Cultivate a Vibrant Community

Background

Pursuant to Section 1.04 of the Town's Charter, the Town Council has the ability to create committees and boards.

On December 16, 2021, pursuant to Resolution No. 2022-025, in response to the Town Council's desire for community involvement and insight into increasing safety on the Town's roadways, the Town Council created the Public Safety and Traffic Committee.

The Town Council wishes to reinstate the Public Safety and Traffic Committee for a six-month period to review and incorporate any updates that may have occurred since the committee last

met and this Resolution is necessary to comply with the Town Council's adopted Committee/Board Policy.

Fiscal Impact/Analysis

N/A

Staff Contact:

Russell Muñiz, Town Administrator

ATTACHMENTS:

Description	Upload Date	Type
Resolution - TA Approved	1/16/2025	Resolution

RESOLUTION NO. 2025 - XXX

A RESOLUTION OF THE TOWN COUNCIL OF THE TOWN OF SOUTHWEST RANCHES, FLORIDA, REINSTATING THE "PUBLIC SAFETY AND TRAFFIC COMMITTEE" FOR A SIX MONTH PERIOD, FOR THE PURPOSE OF ADVISING THE TOWN COUNCIL OF PUBLIC SAFETY AND TRAFFIC RELATED ISSUES; PROVIDING FOR THE BOARD'S GOALS, OBJECTIVES, AND LIMITATIONS; PROVIDING FOR THE APPOINTMENT OF BOARD MEMBERS; AND PROVIDING FOR AN EFFECTIVE DATE.

WHEREAS, pursuant to Section 1.04 of the Town's Charter, the Town Council has the ability to create committees and boards; and

WHEREAS, on December 16, 2021, pursuant to Resolution No. 2022-025, in response to the Town Council's desire for community involvement and insight into increasing safety on the Town's roadways, the Town Council created the Public Safety and Traffic Committee; and

WHEREAS, The Town Council wishes to reinstate the Public Safety and Traffic Committee for a six month period to review and incorporate any updates that may have occurred since the committee last met; and

WHEREAS, this Resolution is necessary to comply with the Town Council's adopted Committee/Board Policy.

NOW THEREFORE, BE IT RESOLVED by the Town Council of the Town of Southwest Ranches, Florida:

Section 1: The above-referenced recitals are true and correct and are incorporated herein by reference.

Section 2: The Town Council hereby reinstates the "Public Safety and Traffic Committee" for a sixth month period.

Section 3: The Public Safety and Traffic Committee shall have the following goals, objectives, and limitations:

- i. To advise the Council of public safety concerns on the Town's roadways, with an emphasis on traffic calming measures to reduce instances of speeding and cut through traffic.

- ii. The Town Staff Liaison shall serve as the conduit to provide the Public Safety and Traffic Committee with any information required to perform its services delineated herein.
- iii. A Public Safety and Traffic Committee Member shall not hold themselves out, in anyway, as being a representative of the Davie Police Department, or as an agent of the Town.

Section 4: The Committee shall be composed of five (5) volunteers, a Council Liaison, and a Staff Liaison. The Mayor, Vice-Mayor and each Council Member shall each appoint one (1) Board Member. Each Member shall serve during his term at the pleasure of the Council Member who appointed him/her to the board. The membership of the Board shall be selected from interested residents. The Board Members shall serve for a six-month term from February 2025 through July 2025.

Section 5: The Council shall announce its Board Member appointments and the Council Liaison at a public meeting, in accordance with the Town's policy concerning Board appointments.

Section 6: The Public Safety and Traffic Committee shall be governed in accordance with Resolution No. 2007-023, as may be amended from time to time. The Committee shall meet as often as the Committee deems necessary. The Committee shall submit, at a minimum, quarterly reports for review by the Town Administrator, which will be presented to the Town Council.

Section 7: Effective Date. This Resolution shall be effective immediately upon its passage.

[Signatures on Following Page]

PASSED AND ADOPTED by the Town Council of the Town of Southwest Ranches, Florida, this 23rd day of January, 2025, on a motion by _____ and seconded by _____.

Breitkreuz _____
Hartmann _____
Allbritton _____
Jablonski _____
Kuczenski _____

Ayes _____
Nays _____
Absent _____
Abstaining _____

Steve Breitkreuz, Mayor

Attest:

Debra Ruesga, CMC, Town Clerk

Approved as to Form and Correctness:

Keith M. Poliakoff, J.D., Town Attorney
1001.001.2025

**This page
intentionally left blank**

REGULAR MEETING MINUTES OF THE TOWN COUNCIL
Southwest Ranches, Florida

Thursday 7:00 PM

September 26, 2024

13400 Griffin Road

Present:

Mayor Steve Breitkreuz

Vice Mayor David S. Kuczenski

Council Member Jim Allbritton

Council Member Bob Hartmann

Council Member Gary Jablonski

Russell Muñiz, Town Administrator

Dan Stewart, Deputy Town Clerk

Emil C. Lopez, Town Financial Administrator

Keith Poliakoff, Town Attorney

A Regular Meeting of the Town Council of Southwest Ranches was held at 13400 Griffin Road in the Southwest Ranches Council Chambers. The meeting, having been properly noticed, was called to order by Mayor Breitkreuz at 7:00 PM. Attendance was noted by roll call and was followed by the Pledge of Allegiance.

Mayor Breitkreuz asked for a moment of silence for the passing of Town resident Bob Parker.

Council Member Allbritton spoke about Mr. Parker and provided details of his viewing and funeral services.

Quasi-Judicial Hearing

3. Waiver of Plat Application No. WP-34-24

A RESOLUTION AND FINAL ORDER OF THE TOWN COUNCIL OF THE TOWN OF SOUTHWEST RANCHES, FLORIDA, APPROVING WAIVER OF PLAT APPLICATION NO. WP-34-24 TO SUBDIVIDE 14.13 NET ACRES OF PROPERTY INTO TWO LOTS OF 3.21 AND 10.92 NET ACRES; GENERALLY LOCATED ON THE EAST SIDE OF HANCOCK ROAD APPROXIMATELY 1,200 FEET SOUTH OF EAST PALOMINO DRIVE; COMPRISING THE NORTH ONE-HALF OF TRACT 27 OF AND ALL OF TRACT 28 IN "THE EVERGLADES SUGAR AND LAND CO. SUBDIVISION OF SECTION 34, TOWNSHIP 50 SOUTH, RANGE 40 EAST", ACCORDING TO THE PLAT THEREOF RECORDED IN PLAT BOOK 1, PAGE 152 OF THE PUBLIC RECORDS OF MIAMI-DADE COUNTY; AUTHORIZING THE MAYOR, TOWN ADMINISTRATOR, AND TOWN ATTORNEY TO EXECUTE ANY AND ALL DOCUMENTS NECESSARY TO PROPERLY TO EFFECTUATE THE INTENT OF THIS RESOLUTION; PROVIDING FOR RECORDATION; AND PROVIDING AN EFFECTIVE DATE.

The following motion was made by Council Member Jablonski, and seconded by Vice Mayor Kuczenski, and passed by a 5-0 roll call vote. The vote as follows: Council Members Allbritton, Hartmann, Jablonski, Vice Mayor Kuczenski, and Mayor Breitkreuz voting yes.

MOTION: TO APPROVE THE RESOLUTION.

4. Public Comment

The following members of the public addressed the Town Council: Mary Gay Chaples, Dee Schroeder, Peter Tossas, John Steven Garate, Debbie Green, Marianne Allen, Jim Laskey, Mike Rodriguez.

5. Board Reports

George Morris spoke on behalf of the Southwest Ranches Parks Foundation. He stated the Bingo at the Barn event that occurred on September 14th, was a big success and that he was looking forward to next year's event. He reminded the Town Council about the upcoming carnival and car show events, and said he would speak about them in more detail at later meetings.

Debbie Green spoke on behalf of the Zero Waste Task Force. She stated the next Solid Waste Executive Meeting would be September 27th, at 9:00 a.m., and the Solid Waste Authority would meet immediately after the conclusion of the Executive Meeting. She stressed the importance of people attending the meetings to provide the Authority the public's opinion on the issues. She said the next Zero Waste Task Force meeting would be October 9th, at 7:00 p.m.

Marianne Allen spoke as the Agricultural Liaison. She talked about the maintenance of equestrian trails around the Town and that more money should be allocated towards maintaining the trails. She spoke about the covers being used for the buried lines in swales and discussed the Florida State Statute regarding protecting large animals such as horses.

6. Council Member Comments

Council Member Jablonski spoke about upcoming events within the Town such as the Holiday Lights Contest submissions due date of December 5th, Hazmat at the Barn happening on September 28th, and the Halloween at the Barn event on October 26th. He stated the Town's 25th Anniversary event would be on June 7th, 2025 at the Rolling Oaks Barn. He talked about the Candidates Forum happening on September 30th at 7:00 p.m. and said it would be streamed live on the Town's YouTube channel. He offered his prayers to Judy Parker on the loss of her husband and spoke about Mr. Bob Parker.

Vice Mayor Kuczenski spoke about Bob and Judy Parker and Mr. Parker's passing. He discussed the Rural Public Arts and Design Board's Halloween House Decorating Contest and said the deadline to enter the contest was October 18th, the judging on October 21st, and that the awards will be announced on the 25th. He spoke about the importance of education on recycling to help fight against the incinerator and provided some examples of proper recycling. He thanked the Town's Volunteer Fire Department for their work to remove a downed tree that was blocking a road in the Town. He asked everyone to keep all of those that may be affected by Hurricane Helene in their thoughts and prayers.

Council Member Allbritton spoke about the Halloween House Decorating Contest. He answered a question regarding potholes asked during public comments, and provided information on how the Town has increased funding towards repairing roads in the Town. He discussed being on the Board of Directors for the Broward League of Cities and talked about meeting Miss Rebecca Thompson, the newly elected School Board representative. He thanked George Morris for his efforts at the Bingo at the Barn event. He addressed a statement made during public comment regarding his membership with the Broward League of Cities.

Council Member Hartmann spoke about Mr. Bob Parker and offered his prayers to Mrs. Judy Parker and the family. He addressed a statement made during public comment regarding his employment at SunPass and addressed another comment regarding researching candidates running for Town Council. He stated that everyone should do their own research on the candidates and the claims that candidates are making before they vote in the election.

Mayor Breitreuz addressed the issue of potholes mentioned during public comment and spoke about the TSDOR project. He discussed the new procedures of the Mosquito Control Division and how it affects the Town and its residents. He stated the Town is trying to work with the County to possibly change the procedures to become more aligned with the Town's needs. He spoke about attending the resiliency round table of Broward County regarding water issues the County is facing in the future and how they planned to be addressed. He spoke about the impoundment area project meant to retain water during heavy rains where the C-11 Canal meets U.S. Highway 27. He said the project should take 5-6 years to complete but the Town would see benefits 3-4 years from now. He also talked about other projects the County is planning, including a seawall.

7. Legal Comments

Town Attorney Poliakoff offered his thoughts and prayers to the Parker family. He addressed comments made during public comment including fees charged to the Town by his firm, legal costs associated with hiring a criminal defense attorney for members of Town staff, and fees paid to the City of Pembroke Pines.

8. Administration Comments

Town Administrator Muñiz expressed his condolences to the Parker family. He discussed receiving an unsolicited proposal for a zero-waste consultant and asked for direction from Town Council regarding creating a proposal for a zero-waste consultant.

A discussion ensued regarding the ways a zero-waste consultant could assist the Town, how much should be allocated for the consultant, and from where the funds should be budgeted. Mayor Breitreuz summarized the duties of the consultant as developing projects the Town can control such as developing recycling and composting plans for the Town, assisting with education and communication on the projects, and to move the Town towards 75-80% recycling. Town Administrator Muñiz explained that the monies were allocated in the 2024 Fiscal Year budget, and those funds will roll over into the 2025 Fiscal Year Fund Balance.

The following motion was made by Vice Mayor Kuczenski, seconded by Council Member Jablonski, and passed by a 5-0 roll call vote. The vote was as follows: Council Members Allbritton, Hartmann, Jablonski, Vice Mayor Kuczenski, and Mayor Breitreuz voting yes.

MOTION: TO DIRECT THE TOWN ADMINISTRATOR TO CREATE A PROPOSAL TO HIRE A ZERO WASTE CONSULTANT AND TO ALLOCATE AN AMOUNT NOT TO EXCEED \$35,000 FROM THE FUND BALANCE.

Town Administrator Muñiz stated that applications for the Town’s Halloween Decorating Contest were available in the Council Chambers for residents. He thanked Town staff for their work and efforts while he was out of the office.

Ordinances – 2nd Reading

9. AN ORDINANCE OF THE TOWN OF SOUTHWEST RANCHES, FLORIDA, AMENDING THE TOWN OF SOUTHWEST RANCHES COMPREHENSIVE PLAN, FUTURE LAND USE ELEMENT POLICY 1.8- P AND THE PERFORMANCE STANDARDS FOR THE US HIGHWAY 27 BUSINESS CATEGORY IN PART TWO OF THE FUTURE LAND USE ELEMENT ENTITLED, “PERMITTED USES IN FUTURE LAND USE CATEGORIES;” PERTAINING TO POTABLE WATER AND SANITARY SEWER FACILITIES REQUIRED TO SERVE DEVELOPMENT DESIGNATED US HIGHWAY 27 BUSINESS CATEGORY ON THE FUTURE LAND USE PLAN MAP; PROVIDING FOR TRANSMITTAL TO THE STATE LAND PLANNING AGENCY AND OTHER REVIEW AGENCIES DEFINED IN F.S. 163.3184(1)(C); PROVIDING FOR RECERTIFICATION; PROVIDING FOR CONFLICT; PROVIDING FOR SEVERABILITY; AND PROVIDING FOR AN EFFECTIVE DATE. (APPLICATION NO. PA-24-2) {Approved on First Reading August 08, 2024}

The following motion was made by Council Member Jablonski, seconded by Council Member Hartmann, and passed by a 5-0 roll call vote. The vote was as follows: Council Members Allbritton, Hartmann, Jablonski, Vice Mayor Kuczenski, and Mayor Breitkreuz voting yes.

MOTION: TO APPROVE THE ORDINANCE ON 2ND READING.

Resolutions

10. A RESOLUTION OF THE TOWN COUNCIL OF THE TOWN OF SOUTHWEST RANCHES, FLORIDA, APPROVING A LEASE AGREEMENT WITH BRITISH IMPORTS OF BROWARD, LLC, DBA JAGUAR WEST BROWARD DBA LANDROVER WEST BROWARD; PROVIDING FOR THE TEMPORARY LEASE OF A PORTION OF THE UNRESTRICTED PROPERTY LOCATED AT THE NORTHEAST CORNER OF GRIFFIN ROAD AND SW 163RD AVENUE FOR THE STORAGE OF NEW AUTOMOBILES; AND AUTHORIZING THE MAYOR, TOWN ADMINISTRATOR AND TOWN ATTORNEY TO EXECUTE SAID AGREEMENT; AND PROVIDING AN EFFECTIVE DATE.

ITEM WAS PULLED FROM MEETING AT REQUEST OF TOWN COUNCIL.

11. A RESOLUTION OF THE TOWN COUNCIL OF SOUTHWEST RANCHES, FLORIDA, APPROVING AN AGREEMENT WITH ARCADIS US, INC. IN THE AMOUNT OF TWO HUNDRED THOUSAND DOLLARS AND ZERO CENTS (\$200,000.00) TO PREPARE A COMPREHENSIVE VULNERABILITY ASSESSMENT; AUTHORIZING THE MAYOR, TOWN ADMINISTRATOR, AND TOWN ATTORNEY TO ENTER INTO AN AGREEMENT; AND PROVIDING AN EFFECTIVE DATE.

The following motion was made by Council Member Jablonski, seconded by Vice Mayor Kuczenski, and passed by a 5-0 roll call vote. The vote was as follows: Council Members Allbritton, Hartmann, Jablonski, Vice Mayor Kuczenski, and Mayor Breitkreuz voting yes.

MOTION: TO REJECT THE NUMBER ONE RANKED COMPANY, ARCADIS US, INC., AS THE AWARDED COMPANY AND TO NEGOTIATE AN AGREEMENT WITH THE SECOND RANKED COMPANY, CHEN MOORE AND ASSOCIATES, DUE TO A CONFLICT OF INTEREST.

12. A RESOLUTION OF THE TOWN COUNCIL OF THE TOWN OF SOUTHWEST RANCHES, FLORIDA, ADOPTING A FUND BALANCE POLICY TO GOVERN NON-SPENDABLE, RESTRICTED, COMMITTED, ASSIGNED, UNASSIGNED FUND BALANCES, AND EMERGENCY FUNDING; PROVIDING FOR SEVERABILITY; AND PROVIDING FOR AN EFFECTIVE DATE.

The following motion was made by Council Member Jablonski, seconded by Vice Mayor Kuczenski, and passed by a 5-0 roll call vote. The vote was as follows: Council Members Allbritton, Hartmann, Jablonski, Vice Mayor Kuczenski, and Mayor Breitkreuz voting yes.

MOTION: TO APPROVE THE RESOLUTION.

13. A RESOLUTION OF THE TOWN COUNCIL OF SOUTHWEST RANCHES, FLORIDA, SUPPORTING THE CREATION OF A TRIPARTY AGREEMENT BETWEEN THE TOWN OF SOUTHWEST RANCHES, THE SCHOOL BOARD OF BROWARD COUNTY, AND THE SOUTH FLORIDA WILDLIFE CENTER RELATING TO THE FUTURE USE OF THE SCHOOL BOARD OF BROWARD COUNTY'S PROPERTY GENERALLY LOCATED OFF OF SHERIDAN STREET BETWEEN SW 185TH WAY AND SW 190TH AVENUE CONTAINING THE PARCEL ID 513901010058; SUPPORTING THE SCHOOL BOARD OF BROWARD COUNTY ENTERING INTO A 99-YEAR LEASE AGREEMENT WITH THE SOUTH FLORIDA WILDLIFE CENTER TO USE THE SOUTHERN SEVEN ACRES OF THE PROPERTY IN CONSIDERATION OF THE TOWN'S REMOVAL OF THE DEED RESTRICTION FOR THE REMAINDER OF THE PROPERTY THAT LIMITS THE PROPERTY TO A PUBLIC SCHOOL/EDUCATIONAL FACILITY; SUPPORTING THE DEVELOPMENT OF THE REMAINDER OF THE PROPERTY FOR RESIDENTIAL USES IN CONFORMITY WITH THE TOWN'S RURAL RANCHES ZONING DISTRICT; AND PROVIDING AN EFFECTIVE DATE.

The following motion was made by Council Member Jablonski, seconded by Mayor Breitkreuz, and passed by a 5-0 roll call vote. The vote was as follows: Council Members Allbritton, Hartmann, Jablonski, Vice Mayor Kuczenski, and Mayor Breitkreuz voting yes.

MOTION: TO APPROVE THE RESOLUTION.

14. APPROVAL OF MINUTES

a. August 8, 2024 Regular Meeting Minutes

The following motion was made by Council Member Jablonski, seconded by Vice Mayor Kuczenski, and passed by a 5-0 roll call vote. The vote was as follows: Council Members Allbritton, Hartmann, Jablonski, Vice Mayor Kuczenski, and Mayor Breitkreuz voting yes.

MOTION: TO APPROVE THE AUGUST 8, 2024 REGULAR MEETING MINUTES.

15. Adjournment

Meeting adjourned at 9:22 p.m.

Respectfully submitted:

Debra M. Ruesga, CMC, Town Clerk

Adopted by the Town Council on this 23rd day of January, 2025.

Steve Breitkreuz, Mayor

PURSUANT TO FLORIDA STATUTES 286.0105, THE TOWN HEREBY ADVISES THE PUBLIC THAT IF A PERSON DECIDES TO APPEAL ANY DECISION MADE BY THIS COUNCIL WITH RESPECT TO ANY MATTER CONSIDERED AT ITS MEETING OR HEARING, HE OR SHE WILL NEED A RECORD OF THE PROCEEDINGS, AND THAT FOR SUCH PURPOSE, THE AFFECTED PERSON MAY NEED TO ENSURE THAT VERBATIM RECORD OF THE PROCEEDING IS MADE, WHICH RECORD INCLUDES THE TESTIMONY AND EVIDENCE UPON WHICH THE APPEAL IS TO BE BASED THIS NOTICE DOES NOT CONSTITUTE CONSENT BY THE TOWN FOR THE INTRODUCTION OR ADMISSION OF OTHERWISE INADMISSIBLE OR IRRELEVANT EVIDENCE, NOR DOES IT AUTHORIZE CHALLENGES OR APPEALS NOT OTHERWISE ALLOWED BY LAW.

REGULAR MEETING MINUTES OF THE TOWN COUNCIL
Southwest Ranches, Florida

Thursday 7:00 PM

October 16, 2024

13400 Griffin Road

Present:

Mayor Steve Breitkreuz

Russell Muñiz, Town Administrator

Vice Mayor David S. Kuczenski

Debra Ruesga, Town Clerk

Council Member Jim Allbritton

Emil C. Lopez, Town Financial Administrator

Council Member Bob Hartmann

Richard Dewitt, Assistant Town Attorney

Council Member Gary Jablonski

A Regular Meeting of the Town Council of Southwest Ranches was held at 13400 Griffin Road in the Southwest Ranches Council Chambers. The meeting, having been properly noticed, was called to order by Mayor Breitkreuz at 7:01 PM. Attendance was noted by roll call and was followed by the Pledge of Allegiance.

Presentations

3. Proclamation - Hindu Heritage Month and Festival of Diwali

Item was pulled at request of staff.

4. Proclamation - National Hispanic Heritage Month

The Town presented a proclamation that recognized September 15th, 2024 through October 15th, 2024 as National Hispanic Heritage Month.

5. Public Comment

The following members of the public addressed the Town Council: Jim Laskey and John Steven Garate.

6. Board Reports

There were no Board Reports.

7. Council Member Comments

Council Member Jablonski spoke about upcoming events within the Town such as the Holiday Lights Contest submissions being due December 5th, the Halloween at the Barn event on October 20th, and the Town's 25th Anniversary event on June 7th, 2025, at the Rolling Oaks Barn. He talked about Water Matters Day scheduled for March 8th, 2025 and the Country Fair and Carnival happening January 16th-20th, 2025. He stated the DMV Flow event would not be happening at the Town because the DMV was assisting in areas affected by the recent hurricanes. He discussed the issue of animals being run over in the Rolling Oaks area and stated that he would like to work with the Town and the Rolling Oaks HOA to resolve the matter by possibly placing additional signage in the area or with rumble strips.

Council Member Allbritton stated that he has received many pothole complaints for his district and around the Town and asked Town Administrator Muñiz to address the issue and explain the policy and procedures for fixing potholes in the Town.

Town Administrator Muñiz discussed the process in place to address potholes in the Town. He spoke about the recent weather conditions, including Hurricane Milton, and other factors that have made it complicated to repair the potholes around the Town. He stated that he and Public Works Director Rody Ley have spoken to the contractor hired to fix the potholes to make sure they are responsive to the letter of the contract. He talked about how areas of the Town are going to be prioritized over others due to their condition, including parts of Stirling Road that were being fixed immediately. He said the Town may also use different contractors to get a quicker response on the issue.

Council Member Allbritton thanked Town Administrator Muñiz and told residents that the issue of potholes is being addressed but stated that it does take time to have them fixed.

Mayor Breitkreuz suggested that Administration research a method of setting a schedule of going out to fix potholes once a week during the rainy season, twice a month during the dry season, and plan for big repairs once a month. He added that the budget should be reviewed to see if we have the funds for creating the schedule or if funds needed to be added.

Council Member Hartmann asked Town Administrator Muñiz if the Town of Davie Police Department could be used to report potholes around Town during their patrols. Town Administrator Muñiz responded that Town staff report potholes as they drive around Town and residents report them as well, but the main issue was trying to repair them in a timely manner and not the actual reporting.

Council Member Allbritton discussed the Rural Public Arts and Design Board Halloween Decorating Contest.

Vice Mayor Kuczenski spoke about the Rural Public Arts and Design Board Halloween Decorating Contest and stated the deadline to enter was October 18th, judging on October 21st, and the awards given out October 25th. He spoke about the National Flood Insurance Program and the Community Rating System. He stated that the Town received a Class 7 Rating, and said that with a Class 7 Rating, residents receive a 15% discount on their flood insurance. He thanked Public Works Director Ley and Public Works staff for their hard work and efforts on helping the Town with receiving that rating.

Council Member Hartmann discussed the Rural Public Arts and Design Board Town Calendar and encouraged everyone to purchase one for \$5.00 at Town Hall.

Mayor Breitkreuz reminded residents that early voting starts on October 21st and encouraged residents to vote. He spoke about the Mayor's Chess Challenge that involves multiple municipalities around the county and that the Town would be hosting the event at Town Hall on Saturday, October 19th. He asked members of the public to come out and participate.

8. Legal Comments

Assistant Town Attorney Dewitt had no legal comments.

9. Administration Comments

Town Administrator Muñiz spoke about the issue of Town residents not being charged the fees for their additional trash carts for Fiscal Year 2024. He stated that due to an oversight, residents with additional carts were not charged the fee for their additional cart but they would be charged for the upcoming year. He said they would not be charged for the prior year but would receive a letter explaining the situation and an invoice for \$312 for Fiscal Year 2025. He clarified that the fees were charged from October to September and that if residents wanted to return their additional carts they could at no charge. He said that if resident had questions they could contact Town Hall to speak to Town Financial Administrator Lopez or himself. He spoke about a discussion item he planned on having on the October 24th Regular Town Council meeting, regarding AARPA funded projects that would ensure all AARPA funds would be spent.

Ordinances – 1st Reading

10. AN ORDINANCE OF THE TOWN OF SOUTHWEST RANCHES, FLORIDA, AMENDING THE CODE OF ORDINANCES TO CREATE A NEW SECTION OF THE TOWN CODE ENTITLED "MERITLESS CODE COMPLIANCE CALLS"; PROVIDING FOR A SERVICE CHARGE AS A PENALTY FOR MORE THAN THREE MERITLESS CODE COMPLIANCE CALLS; PROVIDING FOR PENALTIES; PROVIDING FOR INCLUSION IN THE TOWN'S CODE OF ORDINANCES; AMENDED PROVIDING FOR CONFLICTS; PROVIDING FOR SEVERABILITY; AND PROVIDING AN EFFECTIVE DATE. {Second Reading Scheduled for October 24, 2024}

The following motion was made by Council Member Jablonski, seconded by Vice Mayor Kuczenski, and passed by a 5-0 roll call vote. The vote was as follows: Council Members Allbritton, Hartmann, Jablonski, Vice Mayor Kuczenski, and Mayor Breitkreuz voting yes.

MOTION: TO APPROVE THE ORDINANCE ON 1st READING BY AMENDING THE LANGUAGE "IN A CALENDAR YEAR" TO READ "WITHIN 12 MONTHS".

Resolutions

11. A RESOLUTION OF THE TOWN COUNCIL OF THE TOWN OF SOUTHWEST RANCHES, FLORIDA, CONSENTING TO THE CITY OF COOPER CITY PROVIDING WATER SERVICES TO 6541 MELALEUCA ROAD, REAL PROPERTY LYING WITHIN THE TOWN OF SOUTHWEST RANCHES, FLORIDA; PROVIDING THAT NO FURTHER EXPANSION OF SERVICE SHALL BE PERMITTED WITHOUT THE EXPLICIT WRITTEN CONSENT OF THE TOWN; PROVIDING FOR A CERTIFIED COPY OF THIS RESOLUTION TO BE FURNISHED TO THE CITY OF COOPER CITY; AND PROVIDING AN EFFECTIVE DATE.

The following motion was made by Vice Mayor Kuczenski, seconded by Council Member Hartmann, and passed by a 5-0 roll call vote. The vote was as follows: Council Members Allbritton, Hartmann, Jablonski, Vice Mayor Kuczenski, and Mayor Breitkreuz voting yes.

MOTION: TO APPROVE THE RESOLUTION.

12. A RESOLUTION OF THE TOWN COUNCIL OF THE TOWN OF SOUTHWEST RANCHES, FLORIDA, CONSENTING TO THE CITY OF COOPER CITY PROVIDING WATER SERVICES TO 13100 LURAY ROAD, REAL PROPERTY LYING WITHIN THE TOWN OF SOUTHWEST RANCHES, FLORIDA; PROVIDING THAT NO FURTHER EXPANSION OF SERVICE SHALL BE PERMITTED WITHOUT THE EXPLICIT WRITTEN CONSENT OF THE TOWN; PROVIDING FOR A CERTIFIED COPY OF THIS RESOLUTION TO BE FURNISHED TO THE CITY OF COOPER CITY; AND PROVIDING AN EFFECTIVE DATE.

The following motion was made by Vice Mayor Kuczenski, seconded by Council Member Hartmann, and passed by a 5-0 roll call vote. The vote was as follows: Council Members Allbritton, Hartmann, Jablonski, Vice Mayor Kuczenski, and Mayor Breitkreuz voting yes.

MOTION: TO APPROVE THE RESOLUTION.

13. A RESOLUTION OF THE TOWN COUNCIL OF THE TOWN OF SOUTHWEST RANCHES, AUTHORIZING THE ISSUANCE OF A PURCHASE ORDER TO BRINDLEE MOUNTAIN FIRE APPARATUS IN THE AMOUNT OF TWO HUNDRED TWENTY-EIGHT THOUSAND THREE HUNDRED AND NINETEEN DOLLARS AND ZERO CENTS (\$228,319.00) BY PIGGYBACKING OFF OF THE SOURCEWELL CONTRACT #120921-BLE; TO PURCHASE A NEW ATTACK TRUCK FOR THE SOUTHWEST RANCHES VOLUNTEER FIRE RESCUE DEPARTMENT AND PROVIDING FOR AN EFFECTIVE DATE.

The following motion was made by Council Member Allbritton, seconded by Vice Mayor Kuczenski, and passed by a 5-0 roll call vote. The vote was as follows: Council Members Allbritton, Hartmann, Jablonski, Vice Mayor Kuczenski, and Mayor Breitkreuz voting yes.

MOTION: TO APPROVE THE RESOLUTION.

14. Adjournment

Meeting adjourned at 7:46 p.m.

Respectfully submitted:

Debra M. Ruesga, CMC, Town Clerk

Adopted by the Town Council on this 23rd day of January, 2025.

Steve Breitzkreuz, Mayor

PURSUANT TO FLORIDA STATUTES 286.0105, THE TOWN HEREBY ADVISES THE PUBLIC THAT IF A PERSON DECIDES TO APPEAL ANY DECISION MADE BY THIS COUNCIL WITH RESPECT TO ANY MATTER CONSIDERED AT ITS MEETING OR HEARING, HE OR SHE WILL NEED A RECORD OF THE PROCEEDINGS, AND THAT FOR SUCH PURPOSE, THE AFFECTED PERSON MAY NEED TO ENSURE THAT VERBATIM RECORD OF THE PROCEEDING IS MADE, WHICH RECORD INCLUDES THE TESTIMONY AND EVIDENCE UPON WHICH THE APPEAL IS TO BE BASED THIS NOTICE DOES NOT CONSTITUTE CONSENT BY THE TOWN FOR THE INTRODUCTION OR ADMISSION OF OTHERWISE INADMISSIBLE OR IRRELEVANT EVIDENCE, NOR DOES IT AUTHORIZE CHALLENGES OR APPEALS NOT OTHERWISE ALLOWED BY LAW.

**This page
intentionally left blank**

REGULAR MEETING MINUTES OF THE TOWN COUNCIL
Southwest Ranches, Florida

Thursday 7:00 PM

October 24, 2024

13400 Griffin Road

Present:

Mayor Steve Breitkreuz

Russell Muñiz, Town Administrator

Vice Mayor David S. Kuczenski

Debra Ruesga, Town Clerk

Council Member Bob Hartmann

Emil C. Lopez, Town Financial Administrator

Council Member Gary Jablonski

Keith Poliakoff, Town Attorney

A Regular Meeting of the Town Council of Southwest Ranches was held at 13400 Griffin Road in the Southwest Ranches Council Chambers. The meeting, having been properly noticed, was called to order by Mayor Breitkreuz at 7:06 PM. Attendance was noted by roll call and was followed by the Pledge of Allegiance.

Quasi-Judicial Hearing

3. BBX Site Plan

A RESOLUTION AND FINAL ORDER OF THE TOWN COUNCIL OF THE TOWN OF SOUTHWEST RANCHES, FLORIDA, APPROVING SITE PLAN APPLICATION NO. SP-86-24 BY BBX LOGISTICS PROPERTIES, LLC FOR APPROXIMATELY 335,000 SQUARE FEET OF WAREHOUSE ON THE PARCEL GENERALLY KNOWN AS THE CCA PROPERTY, INCLUSIVE OF ALL OR PARTS OF LOTS 60, 61 AND 62 OF THE REPLAT OF PORTION OF WEST BROWARD INDUSTRIAL PARK; AUTHORIZING THE MAYOR, TOWN ADMINISTRATOR, AND TOWN ATTORNEY TO EXECUTE ANY AND ALL DOCUMENTS NECESSARY TO EFFECTUATE THE INTENT OF THIS RESOLUTION; AND PROVIDING AN EFFECTIVE DATE.

The following motion was made by Council Member Hartmann, and seconded by Council Member Jablonski, and passed by a 5-0 roll call vote. The vote as follows: Council Members Allbritton, Hartmann, Jablonski, Vice Mayor Kuczenski, and Mayor Breitkreuz voting yes.

MOTION: TO APPROVE THE RESOLUTION.

Presentations

4. Proclamation for Horse and Farm Preservation

The Town presented a proclamation that established the Horse and Farm Preservation Act of the Town.

5. Proclamation - Hindu Heritage Month and Festival of Diwali

The Town presented a proclamation that recognized the month of October as Hindu Heritage Month and honored the Festival of Diwali.

6. Proclamation - Red Ribbon Week

The Town presented a proclamation that recognized October 23rd through October 31st as Red Ribbon Week.

7. Public Comment

The following members of the public addressed the Town Council: Melissa Pomales, Carlos Martinez, Marianne Allen, John Steven Garate, Jim Laskey, Debbie Green.

8. Board Reports

Debbie Green spoke on behalf of the Zero Waste Task Force. She stated the next Solid Waste Executive Meeting would be meeting on October 25th at 9:00 a.m. She spoke about the "No Incinerators" yard signs and door hangers in the back of the Council Chambers available for everyone. She said the next Zero Waste Task Force meeting would be November 13th at 7:00 p.m., and they would be showing the "We are All Plastic People" movie at the meeting.

9. Council Member Comments

Council Member Jablonski spoke about upcoming events within the Town such as the Halloween at the Barn event on October 26th at 6:00 p.m., the Water Matters Day event in March, and the Country Fair and Carnival January 16th through the 20th. He talked about the Holiday Lights Contest and said that applications for the contest were due December 5th. He stated the Town's 25th Anniversary event would be on June 7th, 2025, at 10:00 a.m. at the Rolling Oaks Barn. He said the DMV FLOW event would be returning to Town Hall on November 27th. He discussed Broward County possibly creating a Homeless Facility at 198th Avenue and Sheridan Street and said the County was also looking into an area near Dania Beach called the Shaw properties as a possible site as well. He stated the Town should investigate drafting a letter or resolution to encourage the County to choose the Shaw properties location.

Council Member Allbritton discussed early voting in the County and provided the dates for voters. He spoke about the "We Are All Plastic People" movie and encouraged residents to attend the screening of the movie at the Zero Waste Task Force Meeting. He talked about the Halloween Decorating Contest and that all the homes in the contest were decorated by some very talented people and encouraged everyone to drive around Town to see the homes.

Vice Mayor Kuczenski spoke about the Halloween event at the Rolling Oaks Barn on October 26th and said the Sunshine Ranches HOA donated \$200.00 to the event. He discussed the Sun Sentinel article written about Broward County scouting locations in the County to use as a homeless facility. He stated the Town needs to pass a resolution opposing the Sheridan site being selected for the facility.

Mayor Breitkreuz stated that he would have no problems passing a resolution to oppose the facility being built at the Sheridan Street site but wanted more research done to learn what was being planned and how the Town can fight it. A discussion ensued and there was a consensus by the Town Council to have Town Attorney Poliakoff draft a resolution opposing the homeless facility being built at the Sheridan Street site.

Vice Mayor Kuczenski talked about having a Texas Hold 'Em Poker tournament with the proceeds going to the Town's Scholarship Fund. He discussed donating toys to children at the Joe DiMaggio

Children's Hospital and stated that he would be looking into contacting the hospital in an effort for the Town to start a toy drive in cooperation with the hospital. He talked about receiving messages about the Town's bond funds being mismanaged. He spoke to Town Financial Administrator Lopez about the safeguards the Town uses to ensure the funds are not being mismanaged. Town Financial Administrator Lopez described the safeguards Town uses as bi-annual payments to the bank, compliance with the bank's covenant, keeping in compliance with the Town Resolution that authorized the bond purchase, bank requirements and auditing, as well as the Town's contracted auditing services.

Council Member Hartmann spoke about the upcoming election and the Town Charter Amendments on the ballot. He discussed the process on how the charter amendments were created and spoke about the amendments.

Mayor Breitkreuz spoke about the property at 13900 Griffin Road that was mentioned during public comment. He stated that the Town owed it to the property owner, Sunshine Ranches, and the Town residents, that the property owners have a clear view of any restrictions on the property so they could be presented to any potential buyers. He said he would like to set a meeting with the property owners and their attorneys, as well as the Town Attorney and himself to resolve the issue. He talked about the homeless facility and stated that the Town needs to investigate the issue further before he reached out to the County Commissioners.

10. Legal Comments

Town Attorney Poliakoff spoke about the homeless facility and stated that he spoke to Ralph Stone, the Head of Housing for Broward County, and stated that Mr. Stone knew nothing about the Sun-Sentinel article. He said that he believed that there was a meeting regarding what to do with the surplus land in the County the Sheridan Street site was one of the properties listed during the discussion. He said he would research the issue further and contact Senator Rich for more information. He addressed the issue of the 13900 Griffin Road property mentioned in public comment and by Mayor Breitkreuz. He discussed the agreement that was made on the property and the size restrictions. Mayor Breitkreuz stated that clarity was needed on the restrictions of the property and said he wanted a meeting next week regarding the matter. Town Attorney expressed his condolences to the Ansbro family and to the City of Fort Lauderdale on the passing of City Attorney Tom Ansbro.

11. Administration Comments

Town Administrator Muñiz asked the that item 18 be moved after item 21.

The following motion was made by Council Member Hartmann, seconded by Vice Mayor Kuczenski, and passed by a 5-0 roll call vote. The vote was as follows: Council Members Allbritton, Hartmann, Jablonski, Vice Mayor Kuczenski, and Mayor Breitkreuz voting yes.

MOTION: TO MOVE ITEM 18 TO AFTER ITEM 21 ON THE AGENDA

Ordinances – 2nd Reading

12. AN ORDINANCE OF THE TOWN OF SOUTHWEST RANCHES, FLORIDA, AMENDING THE CODE OF ORDINANCES TO CREATE A NEW SECTION OF THE TOWN CODE ENTITLED "MERITLESS CODE COMPLIANCE CALLS"; PROVIDING FOR A SERVICE CHARGE AS A PENALTY FOR MORE THAN THREE MERITLESS CODE COMPLIANCE CALLS; PROVIDING FOR PENALTIES; PROVIDING FOR INCLUSION IN THE TOWN'S CODE OF ORDINANCES; PROVIDING FOR CONFLICTS; PROVIDING FOR SEVERABILITY; AND PROVIDING AN EFFECTIVE DATE. [Approved on First Reading - October 16, 2024}

The following motion was made by Council Member Jablonski, seconded by Council Member Hartmann, and passed by a 5-0 roll call vote. The vote was as follows: Council Members Allbritton, Hartmann, Jablonski, Vice Mayor Kuczenski, and Mayor Breitkreuz voting yes.

MOTION: TO APPROVE THE ORDINANCE ON 2ND READING WITH THE AMENDED PENALTIES ESCALATING FROM THE FIRST THREE CALLS AT NO PENALTY, CALLS 4 THROUGH 6 BEING FINED \$250 PER CALL, AND FOR 7 CALLS AND EACH AFTER, THE FINES WOULD BE \$500 PER CALL.

Ordinances – 1st Reading

13. AN ORDINANCE OF THE TOWN OF SOUTHWEST RANCHES, FLORIDA, AMENDING THE FUTURE LAND USE MAP OF THE TOWN OF SOUTHWEST RANCHES COMPREHENSIVE PLAN BY CHANGING THE DESIGNATION OF APPROXIMATELY 59 ACRES FROM AGRICULTURAL TO US HIGHWAY 27 BUSINESS, GENERALLY LOCATED ON THE EAST SIDE OF US HIGHWAY 27 BETWEEN THE C11 CANAL TO THE NORTH, STIRLING ROAD TO THE SOUTH, AND MENORAH GARDENS CEMETERY TO THE EAST; PROVIDING FOR TRANSMITTAL TO THE BROWARD COUNTY PLANNING COUNCIL AND STATE LAND PLANNING AGENCY; REQUESTING RECERTIFICATION BY THE BROWARD COUNTY PLANNING COUNCIL; AND, PROVIDING FOR AN EFFECTIVE DATE. (APPLICATION NO. PA-20-8)

The following motion was made by Council Member Jablonski, seconded by Council Member Allbritton, and passed by a 5-0 roll call vote. The vote was as follows: Council Members Allbritton, Hartmann, Jablonski, Vice Mayor Kuczenski, and Mayor Breitkreuz voting yes.

MOTION: TO APPROVE THE ORDINANCE ON 1ST READING.

14. AN ORDINANCE OF THE TOWN OF SOUTHWEST RANCHES, FLORIDA, REZONING APPROXIMATELY 59 ACRES FROM A-1 AGRICULTURAL ESTATE DISTRICT TO US HIGHWAY 27 PLANNED BUSINESS DISTRICT, GENERALLY LOCATED ON THE EAST SIDE OF US HIGHWAY 27 BETWEEN THE C-11 CANAL TO THE NORTH, STIRLING ROAD TO THE SOUTH, AND MENORAH GARDENS CEMETERY TO THE EAST; PROVIDING FOR CONFLICT; AND PROVIDING FOR AN EFFECTIVE DATE. (APPLICATION NO. RZ-24-23)

The following motion was made by Council Member Jablonski, seconded by Vice Mayor Kuczenski, and passed by a 5-0 roll call vote. The vote was as follows: Council Members Allbritton, Hartmann, Jablonski, Vice Mayor Kuczenski, and Mayor Breitkreuz voting yes.

MOTION: TO APPROVE THE ORDINANCE ON 1ST READING.

Resolutions

15. A RESOLUTION OF THE TOWN COUNCIL OF SOUTHWEST RANCHES, FLORIDA, APPROVING AN AGREEMENT WITH CHEN MOORE AND ASSOCIATES IN THE AMOUNT OF TWO HUNDRED THOUSAND DOLLARS AND ZERO CENTS (\$200,000.00) TO PREPARE A COMPREHENSIVE VULNERABILITY ASSESSMENT; AUTHORIZING THE MAYOR, TOWN ADMINISTRATOR, AND TOWN ATTORNEY TO ENTER INTO AN AGREEMENT; AND PROVIDING AN EFFECTIVE DATE.

The following motion was made by Vice Mayor Kuczenski, seconded by Council Member Hartman, and passed by a 5-0 roll call vote. The vote was as follows: Council Members Allbritton, Hartmann, Jablonski, Vice Mayor Kuczenski, and Mayor Breitkreuz voting yes.

MOTION: TO APPROVE THE RESOLUTION.

16. A RESOLUTION OF THE TOWN COUNCIL OF THE TOWN OF SOUTHWEST RANCHES, FLORIDA, APPROVING THE FIRST AMENDMENT TO THE AGREEMENT WITH CITRIN COOPERMAN & COMPANY, LLP ("CITRIN COOPERMAN"); AUTHORIZING THE MAYOR, TOWN ADMINISTRATOR, AND TOWN ATTORNEY TO EXECUTE THE AMENDMENT; AND PROVIDING AN EFFECTIVE DATE.

The following motion was made by Vice Mayor Kuczenski, seconded by Council Member Jablonski, and passed by a 5-0 roll call vote. The vote was as follows: Council Members Allbritton, Hartmann, Jablonski, Vice Mayor Kuczenski, and Mayor Breitkreuz voting yes.

MOTION: TO APPROVE THE RESOLUTION.

17. A RESOLUTION OF THE TOWN COUNCIL OF THE TOWN OF SOUTHWEST RANCHES, AUTHORIZING THE ISSUANCE OF A PURCHASE ORDER TO ETR, LLC IN THE AMOUNT OF FOUR HUNDRED NINETY-FIVE THOUSAND AND SEVEN DOLLARS AND ZERO CENTS (\$495,007.00) BY PIGGYBACKING OFF OF THE STATE OF FLORIDA SHERIFFS ASSOCIATION CONTRACT (FSA#23-VEF17.0); TO PURCHASE A NEW FIRE RESCUE UNIT FOR TOWN OF DAVIE FIRE RESCUE PURSUANT TO THE TOWN'S PUBLIC SAFETY AGREEMENT WITH THE TOWN OF DAVIE AS DELINEATED WITHIN RESOLUTION 2023-066; AND PROVIDING FOR AN EFFECTIVE DATE.

The following motion was made by Vice Mayor Kuczenski, seconded by Council Member Hartmann, and passed by a 5-0 roll call vote. The vote was as follows: Council Members Allbritton, Hartmann, Jablonski, Vice Mayor Kuczenski, and Mayor Breitkreuz voting yes.

MOTION: TO APPROVE THE RESOLUTION.

19. A RESOLUTION OF THE TOWN COUNCIL OF THE TOWN OF SOUTHWEST RANCHES, FLORIDA, APPROVING AN AGREEMENT WITH EAST COAST BUILDERS AND DEVELOPERS IN THE AMOUNT OF TWO MILLION SIX HUNDRED SEVENTEEN THOUSAND DOLLARS AND ZERO CENTS (\$2,617,000.00) FOR CONSTRUCTION OF THE AMERICAN RESCUE PLAN ACT (ARPA) FUNDED SOUTHWEST MEADOWS SANCTUARY PARK IMPROVEMENTS PROJECT; AUTHORIZING THE TOWN ADMINISTRATOR TO EXECUTE THE PURCHASE ORDER; AND PROVIDING AN EFFECTIVE DATE.

The following motion was made by Vice Mayor Kuczenski, seconded by Council Member Hartmann, and passed by a 5-0 roll call vote. The vote was as follows: Council Members Allbritton, Hartmann, Jablonski, Vice Mayor Kuczenski, and Mayor Breitkreuz voting yes.

MOTION: TO APPROVE THE RESOLUTION NOT TO EXCEED THE AMOUNT OF \$2,182,000.00 AND TO REMOVE LINE ITEMS AA3, AA4, AA10, AA11, AND AA12 FOR A SAVINGS OF \$435,000.

20. A RESOLUTION OF THE TOWN COUNCIL OF THE TOWN OF SOUTHWEST RANCHES, FLORIDA, ESTABLISHING THE TOWN OF SOUTHWEST RANCHES PERPETUAL MAINTENANCE RESPONSIBILITY FOR THE FRONTIER TRAILS CONSERVATION EASEMENT; PROVIDING FOR SEVERABILITY; PROVIDING FOR CONFLICTS; AND PROVIDING FOR AN EFFECTIVE DATE.

The following motion was made by Council Member Hartmann, seconded by Vice Mayor Kuczenski, and passed by a 5-0 roll call vote. The vote was as follows: Council Members Allbritton, Hartmann, Jablonski, Vice Mayor Kuczenski, and Mayor Breitkreuz voting yes.

MOTION: TO APPROVE THE RESOLUTION.

Discussion

21. ARPA Allocated Projects - Town Administrator Muñiz
Town Administrator Muñiz presented a discussion item to Town Council regarding the ARPA funds the Town received in 2023. He stated that the funds needed to be allocated to projects before the federal deadline or the Town risked losing the federal funds. He spoke about the projects the Town has completed with the funds, which projects the Town has designated to be completed using the funds and made recommendations to the Town Council on which projects should be designated as ARPA projects. A discussion ensued regarding the designation of projects to be paid for using ARPA funding.

The following motion was made by Council Member Jablonski, seconded by Vice Mayor Kuczenski, and passed by a 5-0 roll call vote. The vote was as follows: Council Members Allbritton, Hartmann, Jablonski, Vice Mayor Kuczenski, and Mayor Breitkreuz voting yes.

MOTION: TO APPROVE ALLOCATING ARPA FUNDING TO THE FOLLOWING PROJECTS: THE LED MONUMENT SIGNS, SOUTHWEST MEADOWS SANCTUARY PARK ROADWAY PARKING AND RESTROOM FACILITIES, THE DYKES ROAD PIPING PROJECT, THE TOWN HALL VOICE OVER IP PHONE SERVICE, THE TOWN HALL INTERNET FIBER INSTALLATION, THE TOWN HALL MULTI-PURPOSE STORAGE BUILDING, THE ADD ALTERNATIVES 1, 2, AND 3, TO THE GREEN MEADOWS DRAINAGE PROJECT, AND THE TOWN HALL LOBBY KIOSK FOR THE TOTAL OF \$1,376,200.

18. A RESOLUTION OF THE TOWN COUNCIL OF THE TOWN OF SOUTHWEST RANCHES, FLORIDA, APPROVING THE PURCHASE AND INSTALLATION OF TWO (2) LED MONUMENT SIGNS FROM i2 VISUAL VIA COOPERATIVE PURCHASING AGREEMENT WITH THE FLORIDA BUY STATE COOPERATIVE PURCHASING AGENCY CONTRACT #22-168 IN AN AMOUNT NOT TO EXCEED ONE HUNDRED THIRTY-ONE THOUSAND FOUR HUNDRED AND FORTY DOLLARS AND ZERO CENTS (\$131,440.00); AUTHORIZING THE MAYOR, TOWN ADMINISTRATOR AND TOWN ATTORNEY TO EXECUTE ANY AND ALL DOCUMENTS NECESSARY PROVIDING FOR CONFLICTS; PROVIDING FOR SEVERABILITY; AND PROVIDING FOR AN EFFECTIVE DATE.

The following motion was made by Vice Mayor Kuczenski, seconded by Council Member Hartmann, and passed by a 5-0 roll call vote. The vote was as follows: Council Members Allbritton, Hartmann, Jablonski, Vice Mayor Kuczenski, and Mayor Breitzkreuz voting yes.

MOTION: TO APPROVE THE RESOLUTION AND THE SIGNS TO BE PURCHASED USING ARPA FUNDING.

22. APPROVAL OF MINUTES

a. August 13, 2024 Budget Workshop Minutes- Amended

The following motion was made by Council Member Hartmann, seconded by Council Member Allbritton, and passed by a 5-0 roll call vote. The vote was as follows: Council Members Allbritton, Hartmann, Jablonski, Vice Mayor Kuczenski, and Mayor Breitzkreuz voting yes.

MOTION: TO APPROVE THE AMENDED AUGUST 13, 2024 BUDGET WORKSHOP MINUTES.

23. Appointments

a. Comprehensive Plan Advisory Board Vacancy - Vice Mayor Kuczenski

Vice Mayor Kuczenski advised he would wait until after the General Election to make his appointment.

24. Adjournment

Meeting adjourned at 10:30 p.m.

Respectfully submitted:

Debra M. Ruesga, CMC, Town Clerk

Adopted by the Town Council on this 23rd day of January, 2025.

Steve Breitkreuz, Mayor

PURSUANT TO FLORIDA STATUTES 286.0105, THE TOWN HEREBY ADVISES THE PUBLIC THAT IF A PERSON DECIDES TO APPEAL ANY DECISION MADE BY THIS COUNCIL WITH RESPECT TO ANY MATTER CONSIDERED AT ITS MEETING OR HEARING, HE OR SHE WILL NEED A RECORD OF THE PROCEEDINGS, AND THAT FOR SUCH PURPOSE, THE AFFECTED PERSON MAY NEED TO ENSURE THAT VERBATIM RECORD OF THE PROCEEDING IS MADE, WHICH RECORD INCLUDES THE TESTIMONY AND EVIDENCE UPON WHICH THE APPEAL IS TO BE BASED THIS NOTICE DOES NOT CONSTITUTE CONSENT BY THE TOWN FOR THE INTRODUCTION OR ADMISSION OF OTHERWISE INADMISSIBLE OR IRRELEVANT EVIDENCE, NOR DOES IT AUTHORIZE CHALLENGES OR APPEALS NOT OTHERWISE ALLOWED BY LAW.

**REGULAR MEETING MINUTES OF THE TOWN COUNCIL
Southwest Ranches, Florida**

Thursday 7:00 PM

November 21, 2024

13400 Griffin Road

Present:

Mayor Steve Breitkreuz

Russell Muñiz, Town Administrator

Vice Mayor David S. Kuczenski

Debra Ruesga, Town Clerk

Council Member Bob Hartmann

Emil C. Lopez, Town Financial Administrator

Council Member Gary Jablonski

Keith Poliakoff, Town Attorney

A Regular Meeting of the Town Council of Southwest Ranches was held at 13400 Griffin Road in the Southwest Ranches Council Chambers. The meeting, having been properly noticed, was called to order by Mayor Breitkreuz at 7:09 PM. Attendance was noted by roll call and was followed by the Pledge of Allegiance.

The following motion was made by Council Member Jablonski, and seconded by Vice Mayor Kuczenski, and passed by a 4-0 roll call vote. The vote as follows: Council Members Hartmann, Jablonski, Vice Mayor Kuczenski, and Mayor Breitkreuz voting yes.

MOTION: TO EXCUSE COUNCIL MEMBER ALLBRITTON'S ABSENCE.

Selection of Vice Mayor

3. A RESOLUTION OF THE TOWN COUNCIL OF THE TOWN OF SOUTHWEST RANCHES, FLORIDA, APPOINTING COUNCIL MEMBER _____ AS THE NEW VICE MAYOR OF THE TOWN OF SOUTHWEST RANCHES; AND PROVIDING AN EFFECTIVE DATE.

The following motion was made by Council Member Jablonski, and seconded by Vice Mayor Kuczenski, and passed by a 4-0 roll call vote. The vote as follows: Council Members Hartmann, Jablonski, Vice Mayor Kuczenski, and Mayor Breitkreuz voting yes.

MOTION: TO APPOINT COUNCIL MEMBER HARTMANN AS VICE MAYOR.

4. Public Comment

The following members of the public addressed the Town Council: Alejandro Yilo, Marianne Allen, Dee Schroeder, and John Steven Garate.

5. Board Reports

Harold Gubnitsky spoke on behalf of the Zero Waste Advisory Board. He stated the next Board meeting would be December 3rd, to make up for the cancellation of the September meeting. He spoke about the "re-use" factor being added to the Town's quarterly HHW event. He discussed the Board's efforts working on the language of the Town's Utility Element in the Comprehensive Plan regarding zero-waste, the proposed scope of work for the zero-waste consultant proposal, and grant opportunities

Debbie Green spoke on behalf of the Schools and Education Advisory Board. She stated the "flamingos" for flocking would be starting again in mid-January. She asked for volunteers to help with the effort and said they would be using the Prime Volunteers App to assist with volunteers.

George Morris spoke on behalf of the Aster Knight Southwest Ranches Parks Foundation. He spoke about the Country Fair and Carnival starting on January 16th and provided the hours of operation, the website www.swrcountryfair.com for residents and vendors, and said the presale tickets would be through the Event Brite website.

Marianne Allen spoke on behalf of the Zero Waste Task Force. She discussed the dangers of trash incineration and its byproducts. She spoke about the movie "We Are All Plastic People Now" and the affects plastics have on humans. She talked about Miami-Dade County passing an ordinance for the County banning all single use plastics in county owned facilities. She thanked the candidates and the "Kids Art in the Park" task force, for donating their campaign signs which would be repurposed for various campaigns to raise awareness for ecosystems. She spoke about the Zero Waste Forum being held at the Anne Kolb Nature Center from March 30th to April 5th. She provided the website www.zerowasteforum.com for more information and asked for sponsors for the event. She spoke about the training Broward Clean Air has attended regarding composting. Lastly, she asked the Town and residents for financial support to help continue their efforts in stopping the incinerator and moving towards zero waste.

Marianne Allen spoke as Agricultural Liaison. She discussed herbicides and pesticides lasting in manure for 3-5 years, which is a danger to composting. She said that the horses are being fed grain that is contaminated by herbicides and pesticides and recommended residents to use organic grain. She spoke about bio-sludge and bio-solids contaminating the soil. She thanked the Town Council for the Proclamation for Horse and Farm Preservation.

6. Council Member Comments

Council Member Jablonski spoke about upcoming events within the Town such as Hazmat at the Barn on January 11th, the Country Fair and Carnival January 16th through the 20th, and Water Matters Day on March 8th. He talked about the Holiday Lights Contest and said that applications for the contest were due December 5th. He stated the Town's 25th Anniversary event would be on June 7th, 2025, at 10:00 a.m. at the Rolling Oaks Barn. He said the DMV FLOW event would not be returning to Town Hall until January. He spoke about his concerns on political signs being out for long periods of time and expressed that they should only be put out after a candidate qualifies and stated he would like an ordinance drafted to limit the time. He asked Town Attorney Poliakoff for his opinion on the best course of action for it.

Town Attorney Poliakoff explained that the Town's Code currently states candidates can place their signs out after the Primary Election, however, it does not define which Primary Election. He said that the Town Council can pass an ordinance to amend the Code. A discussion ensued with the Town Council debating placing signs 60 days prior to the election or as soon as candidates qualify to run for election. The consensus was to have the Town Attorney research the matter

further to ensure the legalities of the Town setting specific dates. Town Attorney Poliakoff answered Vice Mayor Hartmann's question regarding the time frame political signs could remain out after the election and he stated that it is 10 days after the election and any signs remaining after that were in violation of the Town Code.

Council Member Kuczenski thanked the residents for re-electing him and stated that it was an honor to serve on the Town Council. He spoke about the Rural Public Arts and Design Board calendars and said they were available for purchase at Town Hall. He talked about Town resident Jenna Iten attending veterinarian school in St. Kitts. He discussed Miami-Dade County passing an ordinance that limits single use plastics at County facilities. He stated he would like the Town to pass a similar ordinance that would preclude vendors from using single use plastics at Town facilities.

A discussion ensued regarding the passing of the ordinance to ban single use plastics at Town facilities and the consensus was to have an ordinance drafted once Town Administrator Muñiz could develop a strategy on how to execute and enforce it.

Vice Mayor Hartmann congratulated Mayor Breitzkreuz and Council Members Kuczenski and Allbritton on being re-elected and spoke about the election results. He discussed how the Town has progressed over the years while at the same time keeping in line with the Town's rural lifestyle.

Mayor Breitzkreuz stated that it is an honor to serve as Mayor for the Town and expressed that he did not run to be the Mayor of just of the residents that voted for him, but to represent everyone in the Town. He congratulated Council Members Allbritton and Kuczenski on their re-elections, and Vice Mayor Hartmann's appointment as Vice Mayor. He stated that he was looking forward to continuing serving with them. He spoke about the issue with the road conditions in the Town and stated that a new process needs to be put in place to repair the roads faster and in a more efficient manner. He asked for a consensus from the Town Council to direct Town Administration to facilitate the change even if it went over the budget.

A discussion ensued regarding ideas on how to improve the process. The Town Council gave Town Administrator Muñiz direction to develop a new strategy on repairing the roads to include hot patching, permanent patching, or adjusting the TSDOR schedule to repair roads on a needed basis, as part of the plan.

Mayor Breitzkreuz addressed an issue of rights of way that was asked during public comment. He expressed that he believes many rights of way in the Town that should be given to the Town residents and how that it would help the Town in the future. He explained the process to the residents and suggested the Town could possibly waive the fees but asked Town Administrator Muñiz to provide more information to the Town Council before it came up for a vote at a later meeting. He asked the Town Attorney to provide more details on the matter. Town Attorney Poliakoff explained the process further for the residents, expressing that they should speak to Public Works Director Ley and included information regarding Broward County fees.

Mayor Breitzkreuz spoke about the Town's involvement in various lawsuits and litigation and stated he would like to have a meeting to discuss all the cases. Town Attorney Poliakoff stated the Town could do an Executive Session if they made the announcement at the current Town Council Meeting. The date of December 4th was settled on for the Executive Session. He discussed the traffic issue at the Circle S development and said that creating a U-turn between the entrance and Tom Thumb convenience store may be the best option to alleviate the traffic. He stated that there would be a cost involved in developing the strategy on fixing the issue but that it would benefit to the Town. Town Administrator Muñiz advised the cost would be approximately \$10,000. Town Council discussed the issue and decided that an amount not to exceed \$11,000 should be used to conduct a study on the matter.

7. Legal Comments

Town Attorney Poliakoff congratulated the members of the Town Council that were re-elected. He stated that he swore in Council Member Allbritton over the phone, so he was an acting Council Member. He announced there would be a Shade Session on December 4th at 6:30 p.m. at Town Hall. He said it was in regards to litigation involving the Town, that it was not open to the public, and a court reporter would be present. He discussed a court of appeals ruling on home-based businesses in the Town that stated if a home-based business impacts more than the individual home then the Town can regulate the home business. He wished everyone a Happy Thanksgiving.

8. Administration Comments

Town Administrator Muñiz congratulated Mayor Breitzkreuz and Council Members Allbritton and Kuczenski on their re-election and stated that he looked forward to working with them. He announced that Kathryn Sims had been hired as the Deputy Town Administrator and introduced her to the Town Council. He discussed the October 24, 2024, Regular Town Council meeting discussion item regarding ARPA funding of \$3,985,292. He stated that the design cost of \$290,963.37 for the Southwest Meadows Sanctuary was inadvertently not included in the discussion and changes had to be made to adjust for the missing funds. He presented to the Town Council the changes to the Town projects which included:

- The Public Safety Facility – Land Acquisition (Appraisals) - \$44,308.00 funded from Unassigned Fund Balance (Reserves)
- The LED Monument Signs - \$131,440 (total project cost) funded from Unassigned Fund Balance (Reserves)
- Public Safety Facility – Engineering, Architecture, & Permitting – funded from Unassigned Fund Balance (Reserves)
- Sanctuary Park – Roadway, Parking, & Restroom facilities – new amount of \$2,272,963.37 (\$1,982,000.00 + \$290,963.37 Design Costs) allocated from ARPA funding
- Town Hall Safety Improvements - \$81,242.00 paid from Unassigned Fund Balance (Reserves)
- Town Hall Multi-Purpose Storage Building - \$50,000 (total project cost) funded from Unassigned Fund Balance

- Green Meadows Drainage Project Add Alternatives 1-3 - \$1,079,172.63 allocated from ARPA funding (total project cost \$1,376,200 - \$166,211 surplus FDEP grant proceeds, \$1,079,172.63 ARPA proceeds, \$130,816.37 Unassigned Fund Balance)

He asked that Town Council approve the changes and that Town Resolution 2025-008 be reconsidered so changes could be made to change the budget line item used to pay for the LED Monument signs.

Mayor Breitreuz discussed the Fund Balance Policy established by the Town and stated that the approximate \$400,000 being taken from the reserve funds was being used on projects to the benefit of Town residents.

The following motion was made by Vice Mayor Hartmann, seconded by Council Member Jablonski, and passed by a 4-0 roll call vote. The vote was as follows: Council Members Jablonski, Kuczenski, Vice Mayor Hartmann, and Mayor Breitreuz voting yes.

MOTION: TO RECONSIDER TOWN RESOLUTION 2025-008 FOR THE SOLE PURPOSE TO CORRECT THE BUDGET ACCOUNT LINE ITEM.

The following motion was made by Vice Mayor Hartmann, seconded by Council Member Kuczenski, and passed by a 4-0 roll call vote. The vote was as follows: Council Members Jablonski, Kuczenski, Vice Mayor Hartmann, and Mayor Breitreuz voting yes.

MOTION: TO AMEND THE BUDGET ACCOUNT LINE ITEM FOR TOWN RESOLUTION 2025-008.

Ordinances – 1st Reading

9. AN ORDINANCE OF THE TOWN OF SOUTHWEST RANCHES, FLORIDA, ADOPTING THE FIVE-YEAR SCHEDULE OF CAPITAL IMPROVEMENTS FOR FISCAL YEARS 2025-2029 PURSUANT TO CHAPTER 163, FLORIDA STATUTES; PROVIDING FOR CONFLICT; PROVIDING FOR SEVERABILITY; AND PROVIDING FOR AN EFFECTIVE DATE.

The following motion was made by Council Member Kuczenski, seconded by Vice Mayor Hartmann, and passed by a 4-0 roll call vote. The vote was as follows: Council Members Jablonski, Kuczenski, Vice Mayor Hartmann, and Mayor Breitreuz voting yes.

MOTION: TO APPROVE THE ORDINANCE ON FIRST READING.

Resolutions

10. A RESOLUTION OF THE TOWN COUNCIL OF THE TOWN OF SOUTHWEST RANCHES, FLORIDA REQUESTING THAT THE MAYOR AND THE TOWN CLERK THROUGH THIS RESOLUTION AUTHENTICATE THE ELECTORATE'S APPROVAL OF FIVE CHARTER AMENDMENTS; DIRECTING THE TOWN CLERK TO INCORPORATE THE APPROVED CHARTER AMENDMENTS INTO THE TOWN'S CHARTER; AND PROVIDING AN EFFECTIVE DATE.

The following motion was made by Council Member Kuczenski, seconded by Vice Mayor Hartmann, and passed by a 4-0 roll call vote. The vote was as follows: Council Members Jablonski, Kuczenski, Vice Mayor Hartmann, and Mayor Breitzkreuz voting yes.

MOTION: TO APPROVE THE RESOLUTION WITH AMENDED LANGUAGE FOR CHARTER AMENDMENT 5 STATING "PROACTIVE CODE" INSTEAD OF "TRANSITION".

11. A RESOLUTION OF THE TOWN COUNCIL OF THE TOWN OF SOUTHWEST RANCHES, FLORIDA, CONSENTING TO THE CITY OF COOPER CITY PROVIDING WATER SERVICES TO 13201 LURAY ROAD, REAL PROPERTY LYING WITHIN THE TOWN OF SOUTHWEST RANCHES, FLORIDA; PROVIDING THAT NO FURTHER EXPANSION OF SERVICE SHALL BE PERMITTED WITHOUT THE EXPLICIT WRITTEN CONSENT OF THE TOWN; PROVIDING FOR A CERTIFIED COPY OF THIS RESOLUTION TO BE FURNISHED TO THE CITY OF COOPER CITY; AND PROVIDING AN EFFECTIVE DATE.

The following motion was made by Council Member Kuczenski, seconded by Council Member Jablonski, and passed by a 4-0 roll call vote. The vote was as follows: Council Members Jablonski, Kuczenski, Vice Mayor Hartmann, and Mayor Breitzkreuz voting yes.

MOTION: TO APPROVE THE RESOLUTION.

12. A RESOLUTION OF THE TOWN COUNCIL OF THE TOWN OF SOUTHWEST RANCHES, FLORIDA, CONSENTING TO THE CITY OF COOPER CITY PROVIDING WATER SERVICES TO 5451 SW 124TH AVENUE, REAL PROPERTY LYING WITHIN THE TOWN OF SOUTHWEST RANCHES, FLORIDA; PROVIDING THAT NO FURTHER EXPANSION OF SERVICE SHALL BE PERMITTED WITHOUT THE EXPLICIT WRITTEN CONSENT OF THE TOWN; PROVIDING FOR A CERTIFIED COPY OF THIS RESOLUTION TO BE FURNISHED TO THE CITY OF COOPER CITY; AND PROVIDING AN EFFECTIVE DATE.

The following motion was made by Council Member Kuczenski, seconded by Council Member Jablonski, and passed by a 4-0 roll call vote. The vote was as follows: Council Members Jablonski, Kuczenski, Vice Mayor Hartmann, and Mayor Breitzkreuz voting yes.

MOTION: TO APPROVE THE RESOLUTION.

13. A RESOLUTION OF THE TOWN COUNCIL OF THE TOWN OF SOUTHWEST RANCHES, FLORIDA, ACCEPTING THE BID RECOMMENDATION FOR IFB 25-02 FROM PREMIER AIR CONDITIONING AND REFRIGERATION, INC. IN THE AMOUNT OF TWENTY NINE THOUSAND FIVE HUNDRED FIFTY TWO DOLLARS AND ZERO CENTS (\$29,552.00) TO FURNISH AND TO INSTALL THREE (3) HVAC UNITS FOR SOUTHWEST RANCHES VOLUNTEER FIRE DEPARTMENT MODULAR AT 17220 GRIFFIN ROAD; APPROVING A BUDGET AMENDMENT TO THE FISCAL YEAR 2024-2025 TOWN BUDGET; AUTHORIZING THE TOWN ADMINISTRATOR TO EXECUTE THE PURCHASE ORDER; AND PROVIDING AN EFFECTIVE DATE.

The following motion was made by Council Member Kuczenski, seconded by Vice Mayor Hartmann, and passed by a 4-0 roll call vote. The vote was as follows: Council Members Jablonski, Kuczenski, Vice Mayor Hartmann, and Mayor Breitreuz voting yes.

MOTION: TO APPROVE THE RESOLUTION.

14. A RESOLUTION OF THE TOWN COUNCIL OF THE TOWN OF SOUTHWEST RANCHES, FLORIDA, APPROVING A PURCHASE ORDER TO RADARSIGN IN THE AMOUNT OF FORTY-SIX THOUSAND DOLLARS AND ZERO CENTS (\$46,000.00) FOR THE PURCHASE OF TWELVE (12) FLASHING SPEED LIMIT SIGNS; AUTHORIZING THE TOWN ADMINISTRATOR TO EXECUTE THE PURCHASE ORDER; AND PROVIDING AN EFFECTIVE DATE.

The following motion was made by Vice Mayor Hartmann, seconded by Council Member Jablonski, and passed by a 4-0 roll call vote. The vote was as follows: Council Members Jablonski, Kuczenski, Vice Mayor Hartmann, and Mayor Breitreuz voting yes.

MOTION: TO APPROVE THE RESOLUTION.

15. A RESOLUTION OF THE TOWN COUNCIL OF THE TOWN OF SOUTHWEST RANCHES, FLORIDA, APPROVING AN AGREEMENT WITH KAILAS CORP FOR CONSTRUCTION OF THE GREEN MEADOWS DRAINAGE IMPROVEMENT PROJECT IN THE AMOUNT OF TWO MILLION ONE THOUSAND FIFTY DOLLARS AND ZERO CENTS (\$2,001,050.00); APPROVING A BUDGET AMENDMENT TO THE FISCAL YEAR 2024-2025 ADOPTED BUDGET; AUTHORIZING THE TOWN ADMINISTRATOR TO EXECUTE THE PURCHASE ORDER; AND PROVIDING AN EFFECTIVE DATE.

The following motion was made by Vice Mayor Hartmann, seconded by Council Member Kuczenski, and passed by a 4-0 roll call vote. The vote was as follows: Council Members Jablonski, Kuczenski, Vice Mayor Hartmann, and Mayor Breitreuz voting yes.

MOTION: TO APPROVE THE RESOLUTION.

16. A RESOLUTION OF THE TOWN COUNCIL OF THE TOWN OF SOUTHWEST RANCHES, FLORIDA, APPROVING A CONTRACT EXTENSION TO THE PROFESSIONAL SURVEYING SERVICES AGREEMENT WITH CRAVEN THOMPSON AND ASSOCIATES; AUTHORIZING THE MAYOR, TOWN ADMINISTRATOR, AND TOWN ATTORNEY TO ENTER INTO AN AGREEMENT; AND PROVIDING FOR AN EFFECTIVE DATE.

The following motion was made by Council Member Kuczenski, seconded by Vice Mayor Hartmann, and passed by a 4-0 roll call vote. The vote was as follows: Council Members Jablonski, Kuczenski, Vice Mayor Hartmann, and Mayor Breitreuz voting yes.

MOTION: TO APPROVE THE RESOLUTION.

17. A RESOLUTION OF THE TOWN COUNCIL OF THE TOWN OF SOUTHWEST RANCHES, FLORIDA, APPROVING A CONTRACT EXTENSION TO THE PROFESSIONAL ENGINEERING SERVICES AGREEMENT WITH CRAVEN THOMPSON AND ASSOCIATES; AUTHORIZING THE MAYOR, TOWN ADMINISTRATOR, AND TOWN ATTORNEY TO ENTER INTO AN AGREEMENT; AND PROVIDING FOR AN EFFECTIVE DATE.

The following motion was made by Council Member Kuczenski, seconded by Vice Mayor Hartmann, and passed by a 4-0 roll call vote. The vote was as follows: Council Members Jablonski, Kuczenski, Vice Mayor Hartmann, and Mayor Breitzkreuz voting yes.

MOTION: TO APPROVE THE RESOLUTION.

18. A RESOLUTION OF THE TOWN COUNCIL OF THE TOWN OF SOUTHWEST RANCHES, APPROVING THE FIRST AMENDMENT TO THE USE AGREEMENT BETWEEN THE TOWN OF SOUTHWEST RANCHES AND THE CIOLI GROUP, LLC, FOR THE SOUTHWEST RANCHES COMMUNITY FARMER'S MARKET; AMENDING THE USE OF THE SITE, PROVIDING FOR INCREASED COMPENSATION TO THE TOWN, AND EXPANDING THE RESPONSIBILITIES, AUTHORIZING THE MAYOR, TOWN ADMINISTRATOR AND TOWN ATTORNEY TO EXECUTE THE FIRST AMENDMENT TO THE AGREEMENT; AND PROVIDING AN EFFECTIVE DATE.

The following motion was made by Council Member Kuczenski, seconded by Vice Mayor Hartmann, and passed by a 4-0 roll call vote. The vote was as follows: Council Members Jablonski, Kuczenski, Vice Mayor Hartmann, and Mayor Breitzkreuz voting yes.

MOTION: TO APPROVE THE RESOLUTION WITH THE FOLLOWING STIPULATIONS:

- a. AMENDING CONTRACT TO A THREE-YEAR RENEWAL ENDING DECEMBER 2027**
- b. PROVIDE ENSURANCES THAT EXIT LANE FROM MARKET IS NOT BLOCKED**
- c. CONTRACT INCLUDES \$500 FOR PORTABLE RESTROOMS AND FEES WILL CONTINUE AFTER PERMANENT RESTROOM FACILITIES ARE BUILT**
- d. MAKE BEST EFFORTS WITH VENDORS TO LIMIT SINGLE USE PLASTICS WITHIN THE NEXT 6 MONTHS**
- e. VENDOR AGREES TO PAY \$175 PER MARKET DAY FOR USE INSTEAD OF \$150 DUE TO EXTENSION THROUGH 2027**

19. A RESOLUTION OF THE TOWN COUNCIL OF THE TOWN OF SOUTHWEST RANCHES, FLORIDA, APPROVING THE TOWN HOLIDAY SCHEDULE FOR CALENDAR YEAR 2025; AND PROVIDING AN EFFECTIVE DATE.

The following motion was made by Council Member Jablonski, seconded by Vice Mayor Hartmann, and passed by a 4-0 roll call vote. The vote was as follows: Council Members Jablonski, Kuczenski, Vice Mayor Hartmann, and Mayor Breitzkreuz voting yes.

MOTION: TO APPROVE THE RESOLUTION.

20. A RESOLUTION OF THE TOWN COUNCIL OF THE TOWN OF SOUTHWEST RANCHES, FLORIDA, APPROVING THE TOWN COUNCIL MEETING SCHEDULE FOR CALENDAR YEAR 2025; AND PROVIDING FOR AN EFFECTIVE DATE.

The following motion was made by Council Member Jablonski, seconded by Council Member Kuczenski, and passed by a 4-0 roll call vote. The vote was as follows: Council Members Jablonski, Kuczenski, Vice Mayor Hartmann, and Mayor Breitreuz voting yes.

MOTION: TO APPROVE THE RESOLUTION.

21. A RESOLUTION OF THE TOWN COUNCIL OF THE TOWN OF SOUTHWEST RANCHES, FLORIDA, APPROVING A YEAR END BUDGET ADJUSTMENT FOR THE FISCAL YEAR 2023-2024 BUDGET; AND PROVIDING FOR AN EFFECTIVE DATE.

The following motion was made by Vice Mayor Hartmann, seconded by Council Member Kuczenski, and passed by a 4-0 roll call vote. The vote was as follows: Council Members Jablonski, Kuczenski, Vice Mayor Hartmann, and Mayor Breitreuz voting yes.

MOTION: TO APPROVE THE RESOLUTION.

Scrivener's Error

22. A RESOLUTION OF THE TOWN COUNCIL OF THE TOWN OF SOUTHWEST RANCHES, FLORIDA, GRANTING A "JOINT DEED OF CONSERVATION EASEMENT – STANDARD (WITHIN BROWARD COUNTY)" TO THE SOUTH FLORIDA WATER MANAGEMENT DISTRICT AND BROWARD COUNTY FOR FRONTIER TRAILS MITIGATION AREA; PROVIDING FOR SEVERABILITY; PROVIDING FOR CONFLICTS; AND PROVIDING FOR AN EFFECTIVE DATE.

The following motion was made by Council Member Kuczenski, seconded by Vice Mayor Hartmann, and passed by a 4-0 roll call vote. The vote was as follows: Council Members Jablonski, Kuczenski, Vice Mayor Hartmann, and Mayor Breitreuz voting yes.

MOTION: TO APPROVE THE RESOLUTION.

23. A RESOLUTION OF THE TOWN COUNCIL OF THE TOWN OF SOUTHWEST RANCHES, FLORIDA, ESTABLISHING THE TOWN OF SOUTHWEST RANCHES PERPETUAL MAINTENANCE RESPONSIBILITY FOR THE FRONTIER TRAILS CONSERVATION EASEMENT; PROVIDING FOR SEVERABILITY; PROVIDING FOR CONFLICTS; AND PROVIDING FOR AN EFFECTIVE DATE.

The following motion was made by Council Member Kuczenski, seconded by Vice Mayor Hartmann, and passed by a 4-0 roll call vote. The vote was as follows: Council Members Jablonski, Kuczenski, Vice Mayor Hartmann, and Mayor Breitzkreuz voting yes.

MOTION: TO APPROVE THE RESOLUTION.

24. APPROVAL OF MINUTES

- a. **August 22, 2024 Regular Meeting Minutes**
- b. **September 12, 2024 First Budget Hearing**
- c. **September 12, 2024 Regular Meeting Minutes**
- d. **September 26, 2024 Second Budget Hearing**
- e. **September 26, 2024 Sole Purpose Meeting - Country Estates**
- f. **September 26, 2024 Sole Purpose Meeting - Sunshine Ranches**

The following motion was made by Vice Mayor Hartmann, seconded by Council Member Kuczenski, and passed by a 4-0 roll call vote. The vote was as follows: Council Members Jablonski, Kuczenski, Vice Mayor Hartmann, and Mayor Breitzkreuz voting yes.

MOTION: TO APPROVE THE AMENDED AUGUST 22, 2024 REGULAR MEETING MINUTES; SEPTEMBER 12, 2024 FIRST BUDGET HEARING MINUTES; SEPTEMBER 12, 2024 REGULAR MEETING MINUTES; SEPTEMBER 26, 2024 SECOND BUDGET HEARING MINUTES; SEPTEMBER 26, 2024 SOLE PURPOSE MEETING MINUTES – COUNTRY ESTATES; AND SEPTEMBER 26, 2024 SOLE PURPOSE MEETING MINUTES – SUNSHINE RANCHES.

24. Adjournment

Meeting adjourned at 10:00 p.m.

Respectfully submitted:

Debra M. Ruesga, CMC, Town Clerk

Adopted by the Town Council on this 23rd day of January, 2025.

Steve Breitzkreuz, Mayor

PURSUANT TO FLORIDA STATUTES 286.0105, THE TOWN HEREBY ADVISES THE PUBLIC THAT IF A PERSON DECIDES TO APPEAL ANY DECISION MADE BY THIS COUNCIL WITH RESPECT TO ANY MATTER CONSIDERED AT ITS MEETING OR HEARING, HE OR SHE WILL NEED A RECORD

OF THE PROCEEDINGS, AND THAT FOR SUCH PURPOSE, THE AFFECTED PERSON MAY NEED TO ENSURE THAT VERBATIM RECORD OF THE PROCEEDING IS MADE, WHICH RECORD INCLUDES THE TESTIMONY AND EVIDENCE UPON WHICH THE APPEAL IS TO BE BASED THIS NOTICE DOES NOT CONSTITUTE CONSENT BY THE TOWN FOR THE INTRODUCTION OR ADMISSION OF OTHERWISE INADMISSIBLE OR IRRELEVANT EVIDENCE, NOR DOES IT AUTHORIZE CHALLENGES OR APPEALS NOT OTHERWISE ALLOWED BY LAW.